

OPEN-FILE REPORT OF-87-03

TRI-TOWNS SUBSIDENCE INVESTIGATION,
WELD COUNTY, COLORADO

A Community-wide Approach to Hazard Evaluation
and Land Use in Undermined Areas

by
Jeffrey L. Hynes

for
Division of Mined Land Reclamation, Inactive Mine Program
This study was funded by U.S. Government Grant No. G5127081.

DOI: <https://doi.org/10.58783/cgs.of8703.wcer4859>



Colorado Geological Survey
Department of Natural Resources
Denver, Colorado
1984

The Colorado Geological Survey is an equal opportunity employer.

CONTENTS

	Page
INTRODUCTION.....	1
PURPOSE OF INVESTIGATION.....	3
Organization of Investigation.....	4
GEOLOGY AND MINING.....	5
Geology.....	5
Mining.....	9
THE SUBSIDENCE PHENOMENON.....	10
Subsidence Models.....	12
Trough-Type Models.....	13
Stable Arch Model.....	16
Harmless Depth.....	17
Surface Effects of Mine Subsidence.....	19
Mine Shafts.....	24
DRILLING AND GEOPHYSICAL INVESTIGATION.....	24
ANALYSIS OF THE DATA.....	27
Mine Features.....	27
Void Space.....	27
Subsidence Analysis and Prediction.....	28
Surface Classification.....	28
Subsidence Determination.....	30
Ground Strain Zones.....	33
Shafts.....	33
More Detailed Drilling.....	36
LAND USE CONSIDERATIONS.....	37
Mitigation Measures.....	38
Presently Developed Areas.....	38
Retrofit and Reconstruction.....	38
New Development.....	39
Shaft Hazard Mitigation.....	41
Avoidance.....	41
CONCLUSIONS AND RECOMMENDATIONS.....	42
Conclusions.....	42
Recommendations.....	43

CONTENTS (CONTINUED)

	Page
ESSENTIAL COMPONENTS OF A COMMUNITY-WIDE SUBSIDENCE INVESTIGATION.....	45
SELECTED REFERENCES.....	49

TABLES

1. NCB classification of mining damage.....	23
2. Categories of protection.....	23
3. NCB strain values in a subsidence profile.....	35

FIGURES

1. Tri-Town Area location and index map.....	2
2a. Drillhole locations and undermined areas (north part).....	6
b. Drillhole locations and undermined areas (south part).....	7
3. Composite stratigraphic section.....	8
4. Trough subsidence over a sub-critical width panel.....	14
5. Trough subsidence over a critical width panel.....	14
6. Trough subsidence over a supercritical width panel.....	15
7. Generalized diagrams of stable arch and bulking process.....	15
8. Detail of stable arch and bulking process.....	18
9. Failure of bulking model due to action of ground water.....	20
10. Relationship of damage to length of structure at different strain levels.....	22
11. Use of caliper log to determine remaining subsidence.....	31
12. Representative subsidence profiles.....	32
13. Slope and strain values for critical and subcritical profiles.....	34
14. Diagram of flexible joints.....	40

PLATES

1. Mining features.....(in pocket)	
2. Subsidence evaluation and hazard classification.....(in pocket)	
3. Representative cross-sections.....(in pocket)	

INTRODUCTION

Coal mining began in the western parts of the Boulder-Weld coal field in the early 1860s and had spread throughout the field by the 1880s. By the turn of the century several large mines were operating in the Tri-Towns Area and underground coal mining persisted in the area until just a few years ago when the Lincoln Mine closed as the result of a fire.

The towns of Firestone, Frederick and Dacono owe their existence primarily to the mining activity and the need for housing and community support for the mine workers. These towns now form the nuclei of growing communities responding to the demand for suburban housing and infrastructure associated with the growth experienced throughout the Front Range urban corridor (fig. 1).

The change in land-use patterns from primarily agricultural to increasingly residential and commercial has caused a shift in the importance of subsidence phenomena associated with the old, abandoned coal mines in the area. While the ground strains and vertical displacements induced by mine subsidence have been just as severe and widespread in the past as those yet to occur, the impact on agricultural land and activities was much less.

It is apparent that structural damage to foundations, utility lines, roadways and other structures is much more serious, and costly, than the lowering of a field requiring some irrigation modification and perhaps releveling. Additionally, the hazard associated with ground disruptions increases as gas lines, power lines, and communications networks are installed in previously undeveloped areas.

Financial problems also increase dramatically as the value of the improved land surface increases. The life savings of an owner may be lost or seriously diminished as a result of subsidence damage to houses and businesses.

The trends discussed above are not unique to the Tri-Towns Area or even the State of Colorado. Many previously rural areas that had been mined in the past are being subjected to varying degrees of development pressure with the attendant problems related to mining and mine subsidence. Seldom is the mine operator or responsible party still available or identifiable so that relief

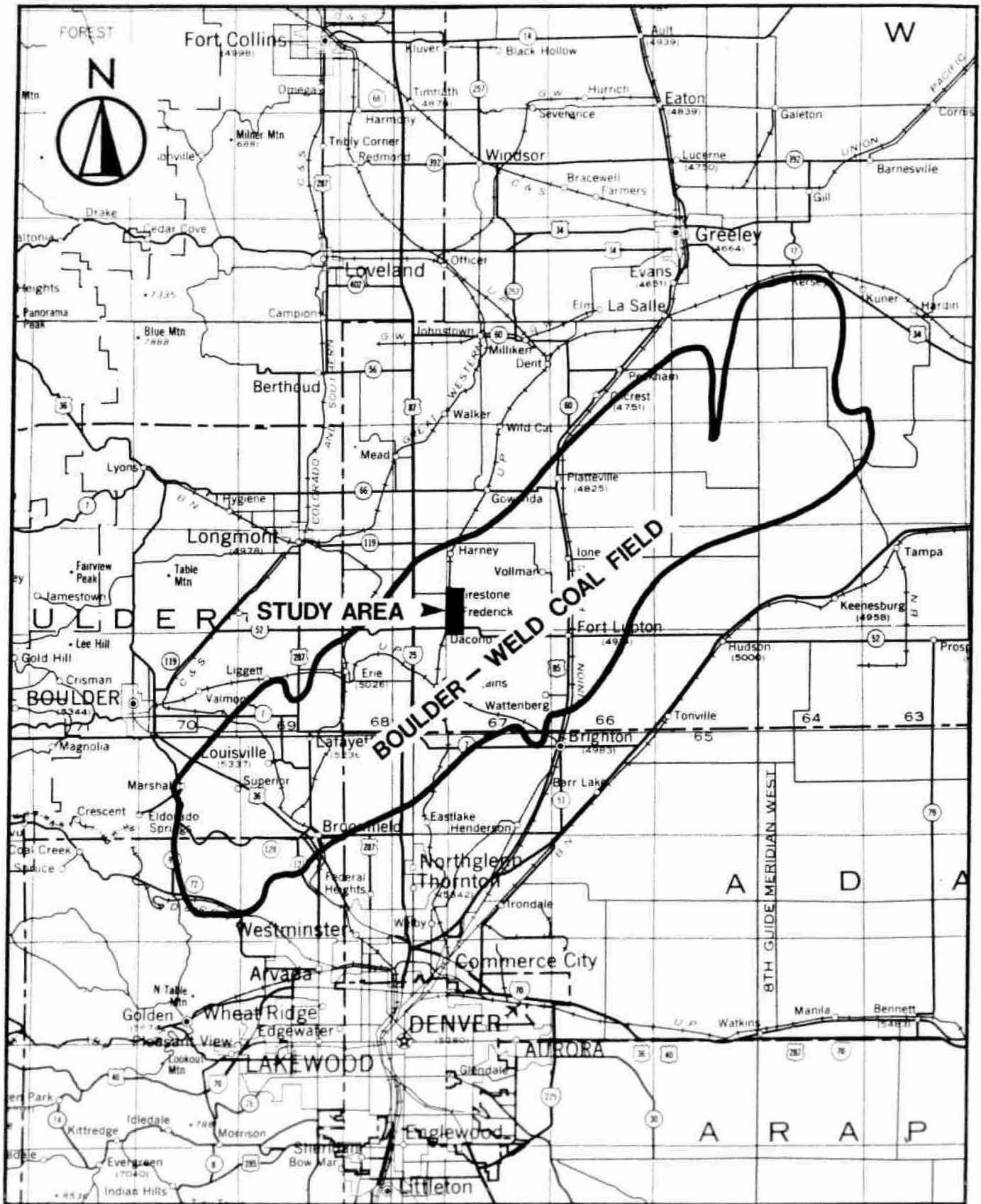

Figure 1. The Tri-Towns area, centrally located between the principal growth centers of the Front Range - Denver-Boulder, Greeley and Fort Collins.

can be sought from, or remedial action required of, those who profited from the mining activity that caused the problem.

As a result, federal legislation was enacted that established the Abandoned Mine Lands Program which assesses a tonnage fee on current coal mine operators and uses the money to assist in remediation of mine-related problems. Portions of these funds are allocated to affected states to be administered by the appropriate state agency for work on specific eligible problems identified by the state.

In the spring of 1983 representatives of the towns of Firestone, Frederick and Dacono, as well as the Tri-Area Planning Council requested that the Colorado Mined Land Reclamation Division conduct a study of potential mine subsidence and its impacts in the Tri-Towns Area. It was subsequently determined that the purpose and scope of such a study was within the purview of the State Inactive Mine Program and funding was provided to the Colorado Geological Survey to carry out this investigation.

This report and accompanying maps and illustrations present the findings and conclusions of that investigation.

PURPOSE OF INVESTIGATION

This study was undertaken by the Colorado Geological Survey under auspices of the Inactive Mine Program of the Colorado Mined Land Reclamation Division for two principal reasons. The first was a response to requests by local governments to provide them with some usable data to guide them in future land-use decisions in the extensively undermined tracts within their jurisdictions. The second was to use the opportunity to test and evaluate various ideas and theories currently used in data acquisition and analysis of undermined areas, in a sense, to perform a prototype study on which further investigations could rely as a model or guide. In terms of both cost and detail, most previous studies were either intensive, site-oriented or broadly reconnaissance in nature. The intermediate level or "second order" investigation undertaken herein is intended to test accuracy and precision of the specific mine maps of the study area, define present underground conditions of critical areas, and to characterize current hazard conditions of the undermined areas to the extent justifiable using recognized subsidence models.

A more specific statement of objectives includes:

1. to evaluate, to the extent possible, subsidence hazards of the Tri-Towns Area through intermediate level investigation.
2. To test various methods for acquiring subsurface data to determine the most cost effective method or combination of methods.
3. To determine and use the most applicable subsidence models for analyzing data of the study; and
4. present the findings, including limitations of methods, in a report.

Organization of the Investigation

The Tri-Town Area Subsidence Investigation consisted of the following components:

1. Determination and analysis of the physical relationship between the surface development, the recorded mine plans and the geology of the study area.
2. Subsurface investigation of the mines and adjacent areas by drilling and geophysical logging (fig. 2).
3. Analysis of the data collected in items 1 and 2 and evaluation of the relevance and applicability of currently accepted models for subsidence evaluation and prediction to the specific situations found in the study area.
4. Preparation of text and illustrations presenting the findings of the study, and classification of the subsidence potential in the area and mitigation and abatement alternatives.

GEOLOGY AND MINING

The geology and mining factors considered to be of significant influence on the subsidence potential of the area are shown on Plate 1. (Plates are in the pocket at the end of this report).

Geology - The general stratigraphic section consists of Quaternary surficial materials composed of sand, silt and clay soils varying from a few feet to as much as 30 feet in thickness unconformably overlying the lower part of the Cretaceous Laramie Formation, which, in turn, conformably overlies the Fox Hills Sandstone, also of Cretaceous age. The thickness of Laramie rocks varies from less than 100 feet to greater than 400 feet as a function of local structure, topography, and erosional history. The mined coal seams in this part of the Boulder - Weld field occur in the lowermost 100 feet of the Laramie formation (see Plate 3). The Fox Hills Sandstone is 150 to 250 feet thick in the study area and grades into the underlying marine shales and sandstones of the Cretaceous Pierre Shale, which is approximately 5000 feet thick in this region of the Denver Basin (fig. 3).

Structurally the area lies on the eastern limb of the Denver Basin with gentle regional dips to the southwest. Locally the attitude of the bedding is controlled by the faulting patterns in the area (Plate 1). Faults in the area can be grouped into two separate categories: 1) general basin faulting associated with the Laramide Orogeny and 2) "growth faults" associated with desposition, dewatering, and consolidation of the sediments.

The basement faults are compatible with the trends in the Denver Basin and do not greatly affect the local situation. The growth faults are responsible for significant variations in the depth and attitude of the coal seams and in the major horst-and-graben structures; they are also responsible for the presence or absence of coal-bearing strata, which in many instances defines the limits of mining.

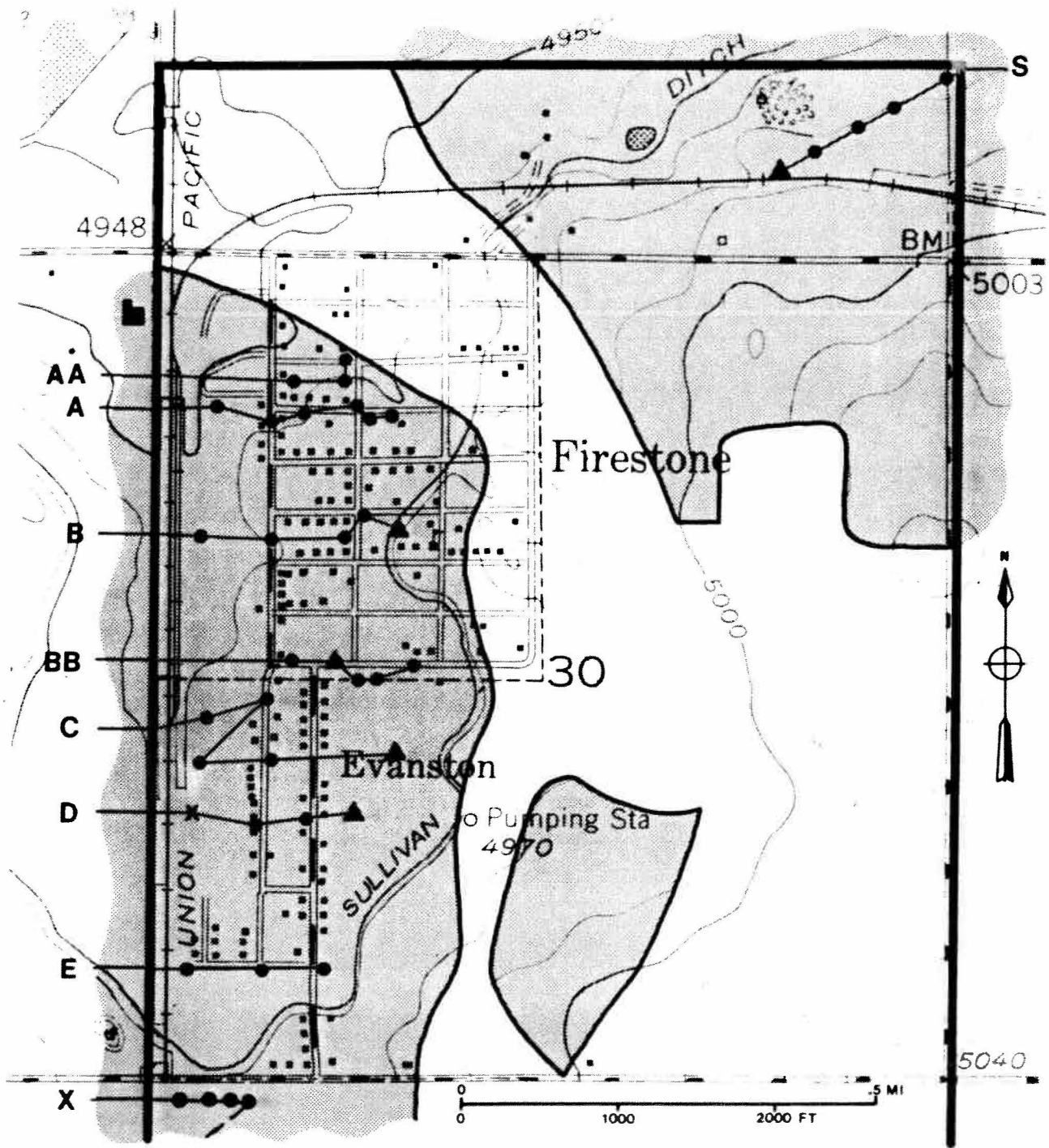

EXPLANATION





-  Extent of mining from E.G. 9[1]
-  Rotary holes
-  Core holes (full & spot)
-  Planned but not drilled holes

Figure 2a. Drillhole locations and undermined areas (north part of study area).

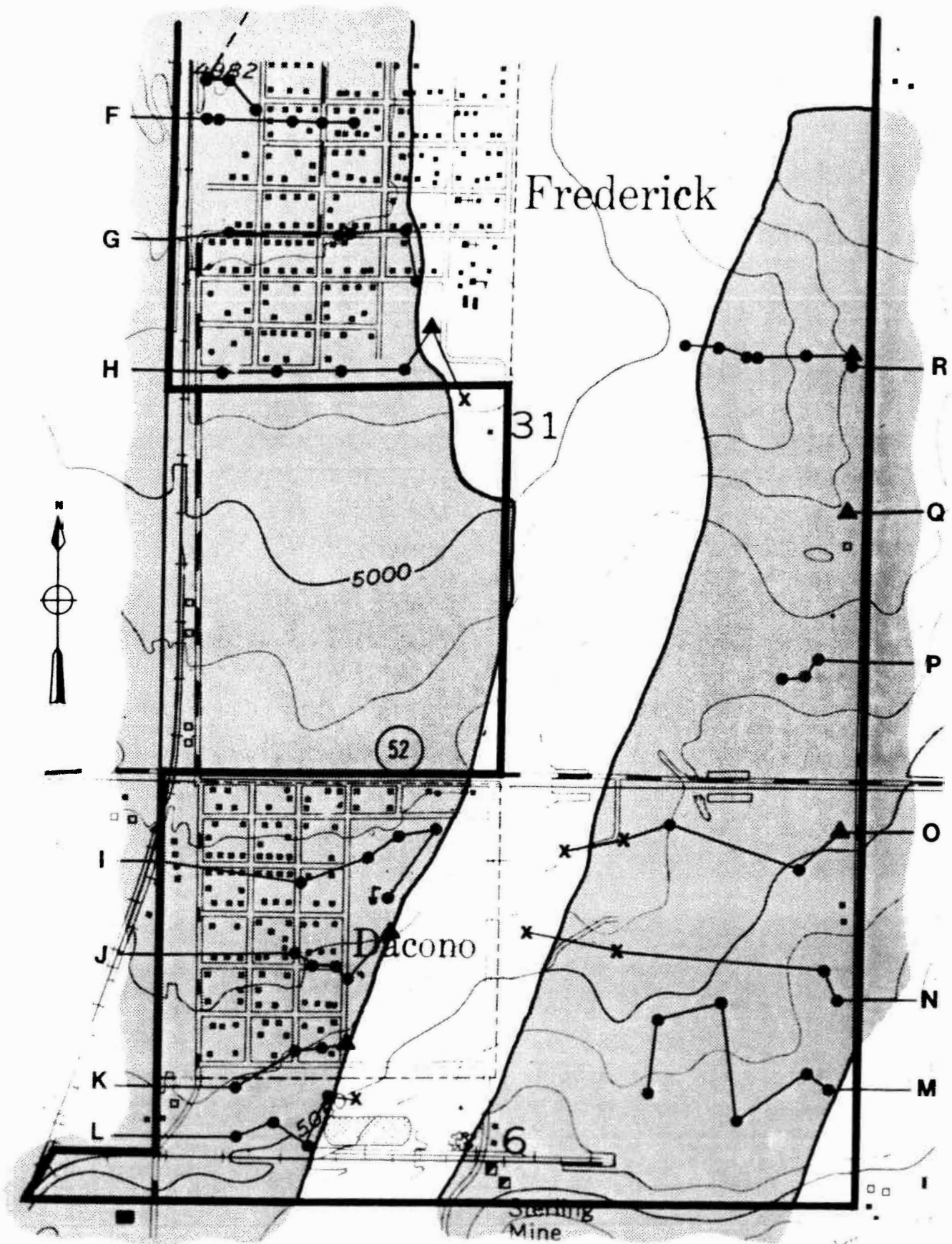

Figure 2b. Drillhole locations and undermined areas (south part of study area).

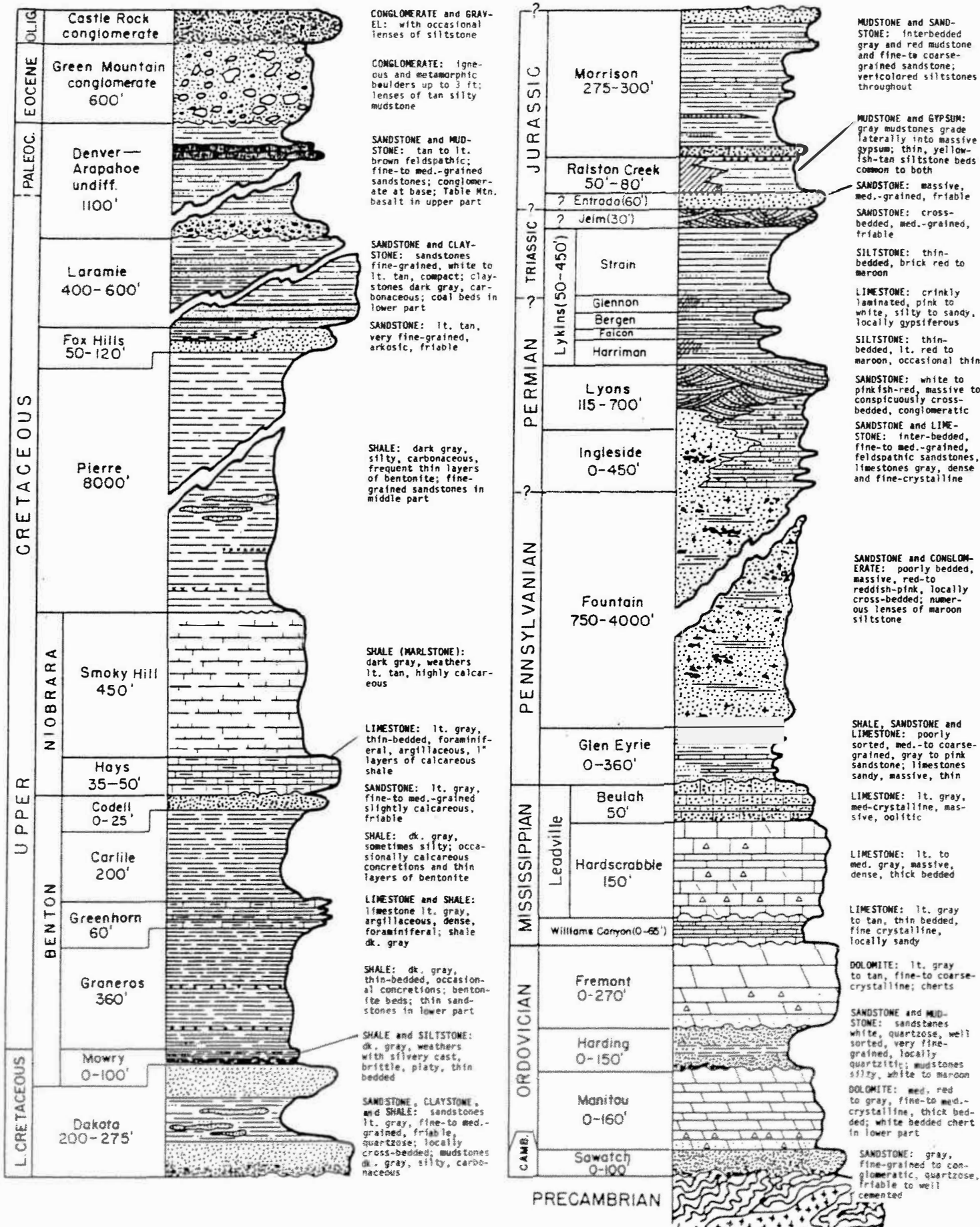

Figure 3. Generalized composite stratigraphic section, Front Range of Colorado (modified from Colorado School of Mines).

Mining - Maps of the following mines were obtained from the Colorado Division of Mines, Denver.

Baum Mine; February 1, 1959
Evans Mine; May 9, 1941
Firestone Mine; March 28, 1944
Frederick Mine; February 2, 1929
Grant Mine; November 9, 1939
Sterling Mine; June 30, 1965
Warwick Mine; July 22, 1912

Dates of the mine maps are used to reference the data shown on the maps. These mine maps were overlain with copies of the town maps for Firestone, Frederick and Dacono acquired from the Weld County Planning Office. All map work was performed at a common scale of 1:2400. Limits of mine influence based on a draw angle of 30 degrees (30°), and significant workings were transferred and/or noted on the base map and used as a basis for locating holes for the drilling program. Subsequent drillhole information represents the majority of new data acquired in the study effort. Fault location information and depth to mining were also taken from mine maps.

The mining method employed in the coal mines under the Tri-Towns Area was room-and-pillar mining. The general procedure was to leave some percentage (30-70%) of the coal in place in the form of pillars to support the roof and keep the workings open to allow for access, ventilation, and so forth, as the heading advanced. Once all the coal in a given area of the mine was taken using this method and there was no need to maintain that portion of the mine open, the pillars would be pulled as the miners retreated from the heading.

Ideally, pillars would be pulled in a systematic, orderly fashion until signs of incipient instability were noted in the roof. At that point the area was abandoned and presumably, subsidence would occur shortly thereafter. In many cases however, pillar extraction was random and incomplete, and in others, the initial signs of instability were interpreted cautiously and subsidence did not immediately follow abandonment.

Compounding this situation is the fact that the locations, dimensions and structural nature of the final pillar configuration were often inaccurately or schematically recorded, if at all.

This situation is not surprising given the principal interest of the mining operators - production and safety, and the relatively trivial impacts of subsidence on the utility of the agricultural land surface. In the majority of cases where the surface had been developed and was more valuable, the pillars were left intact or mining was not conducted below that area.

The results of these variables on pillar extraction are generally random, poorly recorded (and in some instances actually falsified) mapping of pillars in significant portions of the undermined areas. The almost certain presence of remnant pillars, and the inability to precisely locate them seriously complicate subsidence prediction with respect to location, magnitude, and time of incidence.

In order to make any meaningful conclusions regarding the subsidence potential in a given area, a great deal of reliance must be placed upon the mine maps for that area. This makes it critically important to verify the location, accuracy and configuration of the workings as indicated on the best and most recent maps available. This entails two steps:

1. Location and registration of landmarks and control points that are common to both the mine maps and the existing or proposed surface development and
2. Subsurface investigations by borehole and geophysical methods to evaluate the physical conditions of the workings, and the reliability and accuracy of information portrayed on the mine map.

These steps will be described as they apply to specific details of this study in the appropriate sections which follow.

THE SUBSIDENCE PHENOMENON

The following discussion is intended to present the general nature of mine subsidence and its surface effects. Those desiring a more detailed technical

explanation or rigorous analytical treatment are referred to any of several technical presentations in the Selected References section found toward the end of this report (5, 6, 15, 24).*

Subsidence is defined as the lowering of the ground surface as a result of loss of support or bearing below. There are several common mechanisms which result in subsidence, most notably, extraction of underground fluids, solution of chemical constituents in rocks, hydrocompaction, and of course, mining. The ensuing discussion will deal only with subsidence resulting from underground mining.

The factors we need to know about subsidence at any given point are:

1. What will be the magnitude of the vertical and horizontal displacements?
2. How large an area of the surface will be affected by a mine of given dimensions?
3. When and how will the displacements occur, or have they occurred already?
4. What effect will the subsidence have on a given structure, either existing or proposed?

The principal driving force for subsidence is gravity and thus it represents a universal trend of ground lowering over the voids left by underground mining. The actual behavior of the rock and soil mass above an underground void is determined by many factors, some of which function independently and some in conjunction with other factors. How the overlying materials behave in a particular situation will determine how the ground surface reacts, and this, in turn, controls the displacements and stresses to which structures built upon the ground will be subjected. The specific nature of this behavior can dramatically affect the answers to the above questions.

* Numbers in () refer to numbered entry in Selected References of this report.

The primary factors affecting the subsidence process are:

1. Mining method and final configuration of the mine voids; i.e. depth, width, height of extraction, presence of supporting or stowed materials in the void,
2. Physical properties of the overlying and immediately underlying strata, i.e. compressive and tensile strength of the rocks, presence or absence of jointing and fracturing, swelling and/or slaking characteristics of the rocks and soil, and
3. Hydrologic conditions; i.e. water table elevation with respect to mining elevation, seasonal variations, influence of pumping, perched water on top of bedrock.

If the mine is operating or open, the data in item 1 can be obtained by direct observation. In the Tri-Towns Area this is not possible and this information must be obtained by review of available mining records and verified to the extent possible by field investigation. Some of the information in item 2 can be obtained by sampling and testing and some from observation of outcrops or other exposures of the soil and rock in the immediate area. A great deal of these data are represented by ranges of values or qualitative ranking rather than specific numerical values. The information in item 3 can usually be acquired from mining and subsequent drilling records in the area, but may have to be augmented by obtaining site specific information in some cases.

Subsidence Models

Generally the problems of acquisition and evaluation of the data in item 2 make detailed mathematical analysis impossible without some rather significant generalizations and simplifying assumptions. In some cases an easier approach is to develop empirical relationships based upon actual observations in mined areas. This is the method used by the National Coal Board (NCB) of Great Britain to develop the Subsidence Engineer's Handbook (24).

Other similar models have been prepared for various mining districts in Europe and Africa. All have one common element - They are designed to evaluate long wall mining which makes the direct use of the method in the room and pillar mining of the Tri-Towns Area inapplicable in many instances. However, where pillar extraction is shown to be essentially complete and this is verified by subsurface investigations, the model appears to give reasonable and somewhat conservative results. Given the absence of a substantial body of subsidence data in the Boulder-Weld Coalfield on which to derive a local model, a conservative, proven model is the best alternative.

Each site then must be evaluated to determine if the mining conditions are well known enough and can be shown to approximate the situation for which the NCB model was developed.

Factors to consider in this evaluation are: a) mine geometry, b) degree of total pillar removal and pillar size, and c) thickness and physical characteristics of overlying rock and soil.

For example, a random distribution of remaining pillars or an irregularly shaped mine plan may deviate significantly from the model and thus render it inapplicable.

In some cases, limitations in the data may allow the investigator to only answer some of the necessary questions with certainty. This may still warrant testing of the model for those specific purposes, especially in the absence of an alternative methodology.

Trough-Type Models - The NCB Model can best be described as an empirical profile function. This means that curves and graphs representing the salient mathematical relationships of the model have been derived from actual field measurements and reliable results should be obtained by using the data from a similar area in the model. The principal feature of the model is a subsidence trough essentially symmetrically superimposed on a long wall mining panel (see figs. 4,5 & 6).

The most significant parameters the model was designed to determine are: a) vertical subsidence, b) horizontal displacement, c) horizontal ground strain, and d) ground surface tilt and curvature.

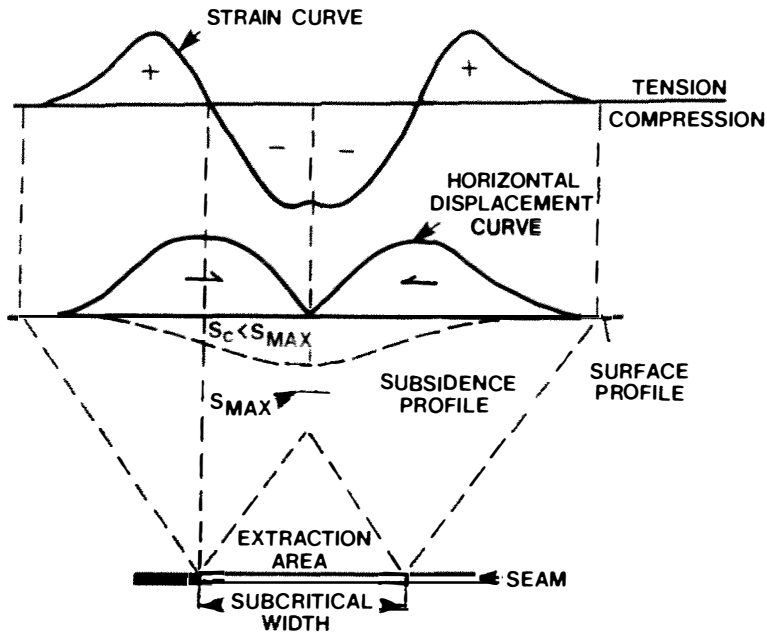

Figure 4. Trough subsidence over a panel of subcritical width showing vertical and horizontal displacements and horizontal strain. Note that vertical subsidence does not equal S_{max} (modified from Zwartendyk, 1971 and Baker, 1974).

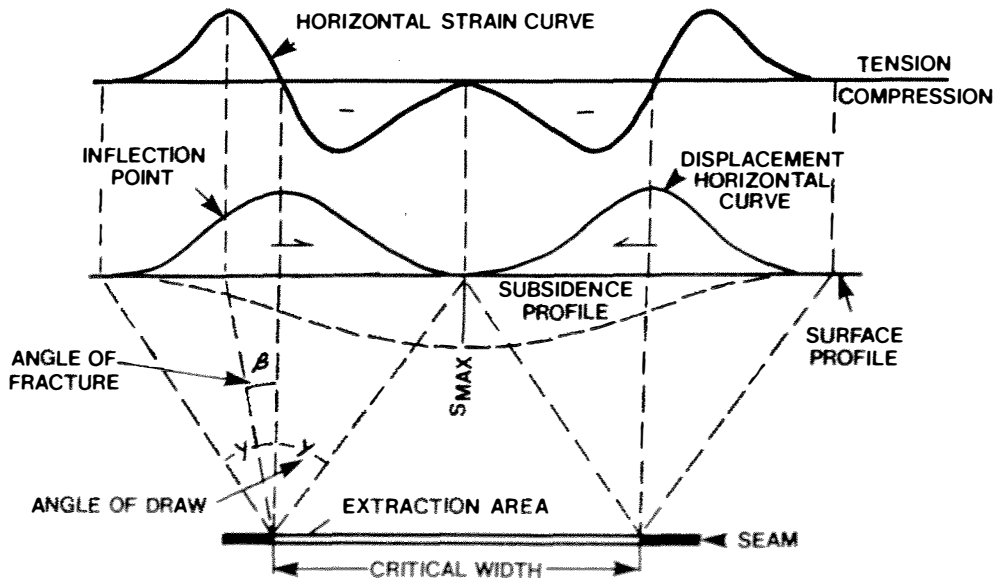

Figure 5. Trough subsidence over a panel of critical width showing vertical and horizontal displacements and horizontal strain. Note that vertical subsidence equals S_{max} only at center of trough (modified from Zwartendyk, 1971 and Baker, 1974).

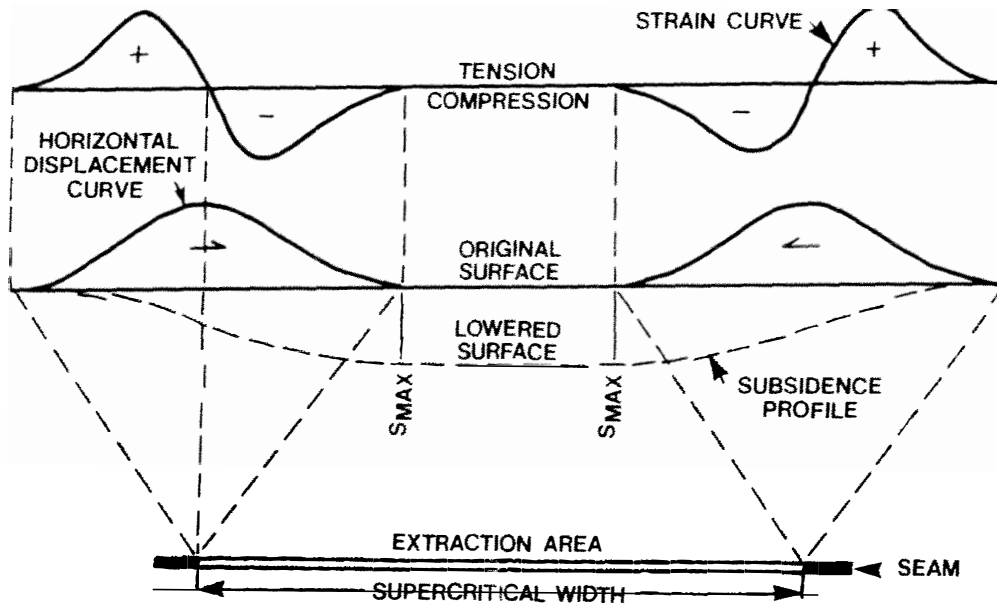

Figure 6. Trough subsidence over a panel of supercritical width showing vertical and horizontal displacements and horizontal strain. Note that vertical subsidence equals S_{max} in a wide zone in the middle of the trough. Also, horizontal strain goes back to zero in this zone (modified from Zwartendyk, 1971 and Baker, 1974).

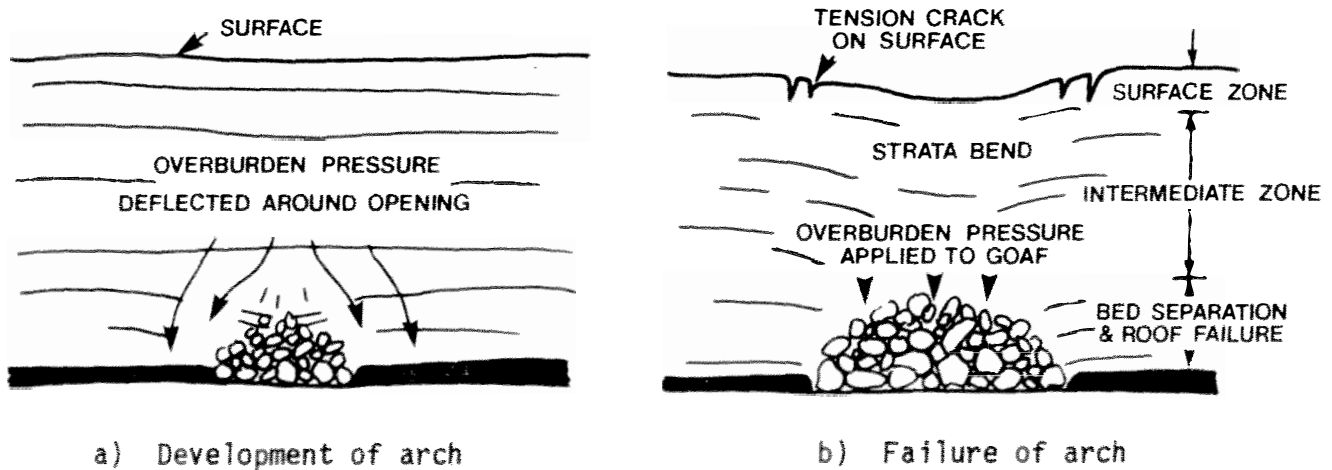

Figure 7. Stable arch/bulking; (a.) overburden supported by rubble column, (b.) trough-like subsidence above failed arch (modified from Kapp and Williams, 1972 and Baker, 1974).

The magnitudes of these factors are determined by the relationships between the width, depth, and height of the extraction zone. They are also affected by the physical properties of the overlying strata but this is already incorporated into the curves.

The procedure consists of determining S_{max} (maximum possible subsidence) for the actual mining conditions first and then using this value to determine the remaining values.

If it is determined that the mining plan does not represent a condition similar to the long wall (total extraction) model, then the NCB methodology should not be applied or should be applied with definite reservations as to the validity of the results.

Stable Arch Model - Another useful model for analysis of room-and-pillar workings is a combination of stable arch theories and bulking. As above, it must be demonstrated that the model is appropriate for the actual mining conditions under consideration. This will require subsurface investigation and documentation as did the NCB model and to some extent the data collected in a detailed investigation will indicate which approach to use.

The bulking/stable-arch model consists of a determination of the volumetric increase associated with the disaggregation of the roof rock as it breaks loose and falls to the floor of the mine cavity (bulking) and the determination of the height of the stable arch that can be expected to form in the rock above a void of given dimensions (fig. 7).

If it can be shown that bulking will result in the void being filled with the looser material derived from roof fall before the height and configuration of the stable arch is achieved, then it is reasonable to assume that the void will not propagate to the surface (15). This should prevent pothole failures which could seriously affect structures or other improvements (fig. 7a).

If a height greater than that of the stable arch is needed to "fill" the void with rubble from the roof, then the possibility of caving proceeding to the surface is much more likely. This is due to the changes in the rock properties at the arch boundary and attendant reduction of their strength due to

weathering and mechanical alteration. Through time, as rock properties change in the zone of the arch, the arch migrates upward to the surface causing potholes. Alternatively, the overlying strata can sag into the void inducing trough-like subsidence (fig. 7b). It is currently not possible to predict the magnitudes of displacements and strains with any degree of reliability using these models (19).

When the void is filled prior to reaching stable arch height subsidence effects do not reach the surface. As the rock above tends to break and "fall" into the "loose" space below, the rubble provides some bearing strength to the overlying strata and props up the remaining roof. This acts to halt the upward migration of the void and the roof rock above this zone is not exposed to any significant changes in stress or exposure to weathering phenomena, effectively establishing a new equilibrium condition with a stable roof (fig. 8).

While the bulking/stable arch model is somewhat easier to understand and apply to room-and-pillar workings, the level of subsurface investigations needed to accurately evaluate the rock properties needed to make the determinations, to demonstrate that the model is appropriate to the mining features in question and to evaluate the effects of lateral and horizontal discontinuities in the overburden may be substantial. This is especially true with overburden that is as variable and discontinuous lithologically as the lower Laramie Formation in the Boulder-Weld field.

Harmless Depth - If stable-arch considerations are removed from the model and reliance on surface protection is placed solely on bulking, the concept of harmless depth is developed. Basically the theory states that the volumetric increase will close the void as it propagates upward so long as the column of overburden rock is thick enough to generate the volume of the original cavity. For example, if the bulking factor were 1.1, then it would take 10 feet of rock column to expand enough to fill a 1 foot original void or 100 feet of column to fill a 10-foot void. So, if the mining extraction were 10 feet high, the harmless depth would be 100 feet. If the bulking factor were 1.05, the harmless depth for a 10-foot void would be 200 feet by the same analysis.

The appeal of this model is its ease of application to large areas and the necessity for much less subsurface investigation, data acquisition, testing and

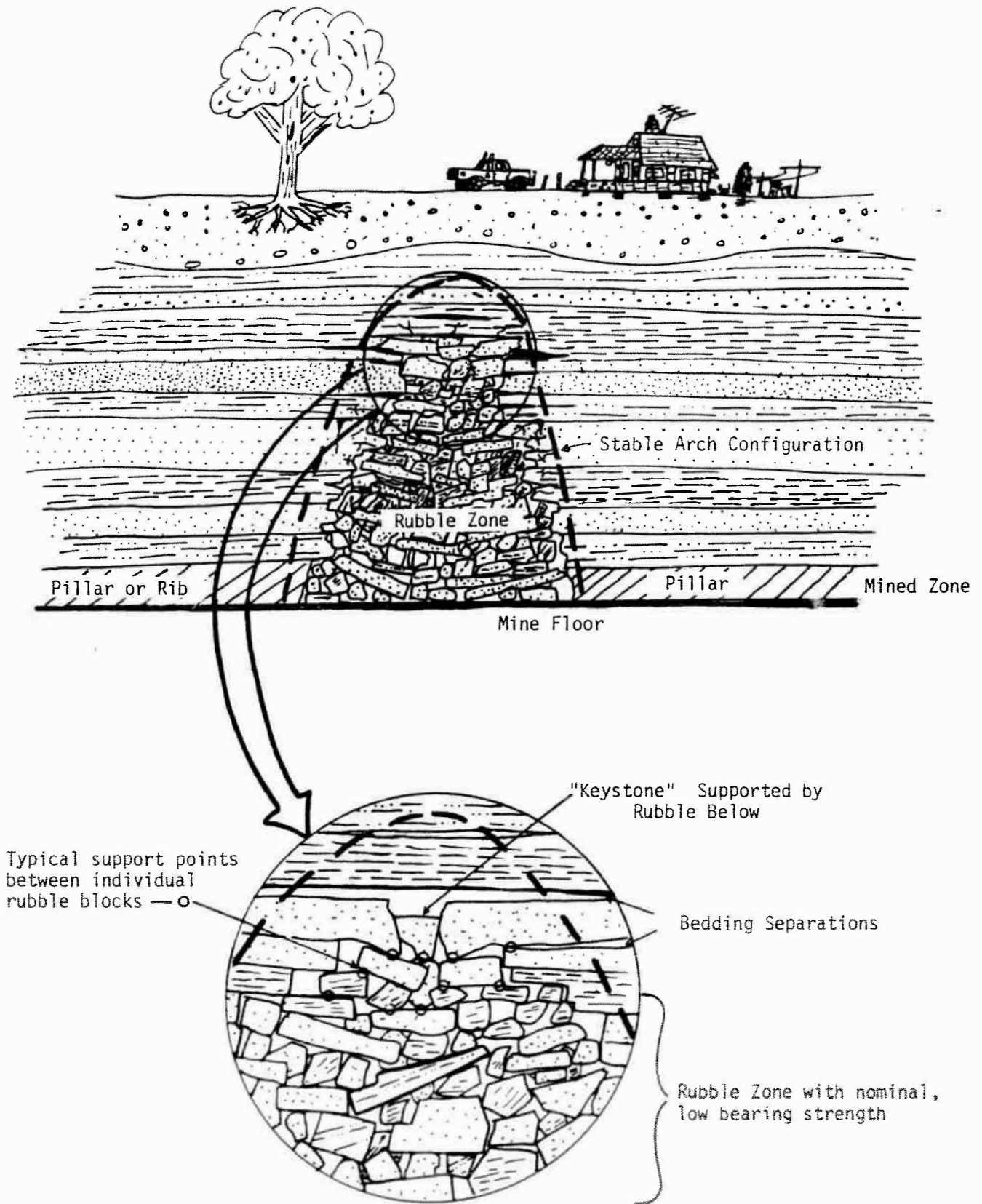

Figure 8. Stable arch/bulking model.

analysis. The principal disadvantage to the model is the numerous examples of specific cases or situations in which it does not work.

For example, bulking factors for siltstones and sandstones are in the range of 1.25 to 1.3, shale and claystones exhibit factors of 1.1 to 1.2 as determined in laboratory tests. Given a section composed of 2/3 shale and claystone and 1/3 siltstone and sandstone, using minimum values, the composite bulking factor would be 1.15. With this bulking factor an 8 foot seam would require only 53.3 feet to achieve harmless depth. If the bulking factor were reduced by a safety factor of 2, 107 feet would be the harmless depth. Yet surface subsidence of several feet was observed over the Baum Mine with a 7 to 8 foot extraction at a 300 foot depth in the southern end of Dacono.

Obviously, other factors operate to seriously reduce the bulking factor (if not eliminate it altogether) or render it inapplicable to many situations. One of these factors clearly is ground water movement in and above the mined interval. This can result in piping or washing through of large volumes of fine sediment, bedrock disintegration or squeezing of a column of remolded and wet clays (fig. 9). Another probably is faulting or severe fracturing and jointing in the roof rock.

Surface effects of mine subsidence

The principal surface effects of subsidence that result in damage or destruction of structures and engineering works such as housing or roadways and pipelines are vertical subsidence, horizontal ground strain, tilt and curvature.

Vertical subsidence may or may not cause any significant problems to a structure depending on whether it is uniform lowering of the ground surface or if there is a differential component to the displacement. Differential subsidence of as little as a few inches can cause serious damage to lightly reinforced or unreinforced foundations. Uniform lowering of an area may have little or no effect on the integrity of structures within the area but may cause problems associated with grade and drainage changes or reversals of flow in ditches, streams or gravity sewer lines (3,6,24).

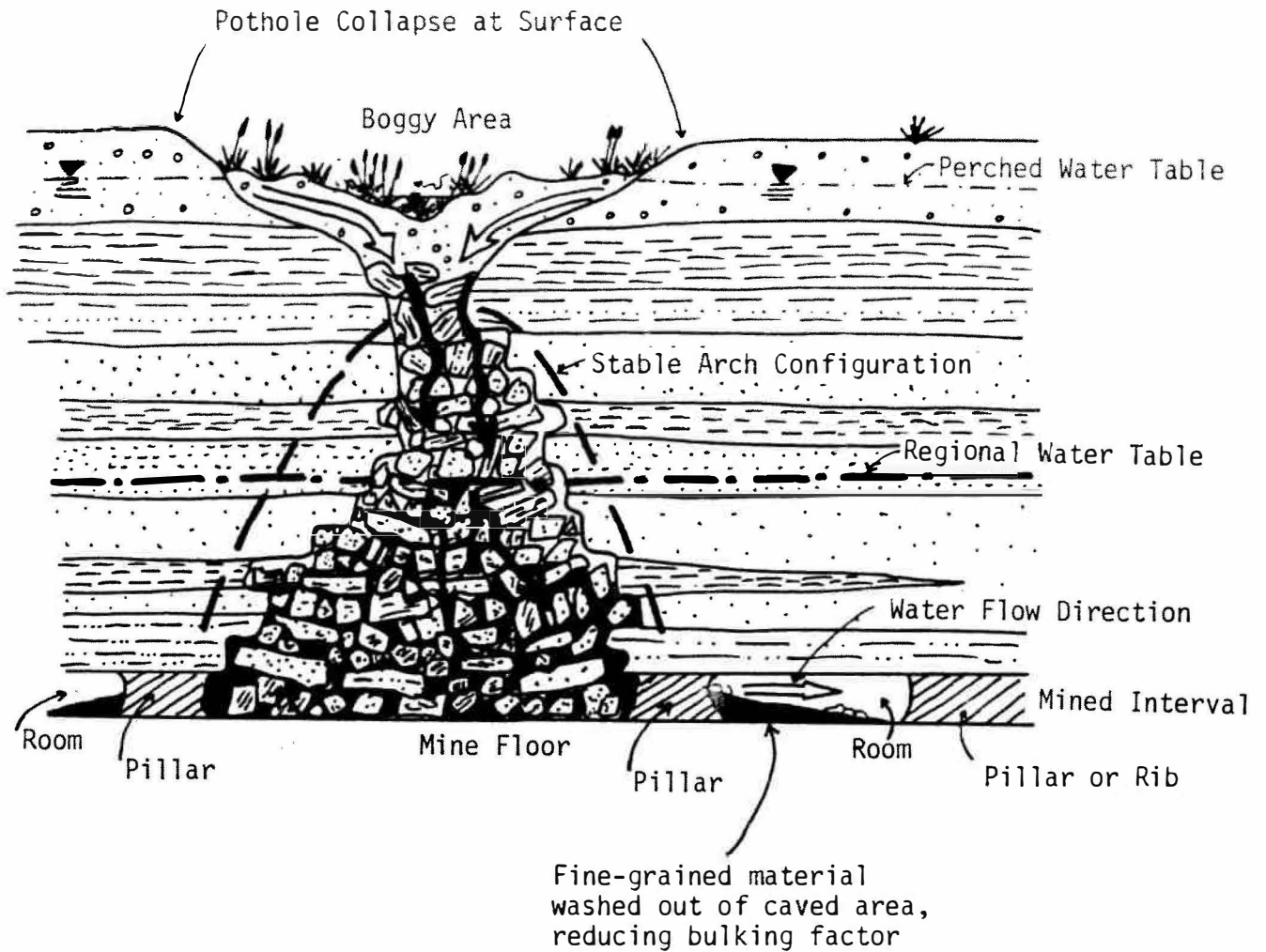

Figure 9. Failure of bulking model due to the action of ground water. Keystone is unsupported due to reduced bulking factor caused by granular disintegration and migration of roof material into the voids surrounding open workings. Upward caving drains surface water inducing pothole collapse and possible piping failures.

Horizontal ground strain is perhaps the most important and most potentially damaging aspect of subsidence. Strain is a measure of the change in length of an object when under stress when compared to its original length. Shortening is defined as in compressive strain (-) and lengthening as tensional strain (+). Conventional foundations, i.e. lightly reinforced concrete and masonry are extremely vulnerable to tensional strain. Values as small as .001 (approximately 1/2 inch in 50 feet) can cause noticeable distortions in residential structures (fig. 10). Strain values of .002 can cause deformations and damage necessitating minor repair work.

Orientation of structures with respect to the strain distribution and specifically, zones of weakness such as rows of doorways or banks of windows can considerably alter the vulnerability of a particular structure to a given level of ground strain.

Tilt is rarely a serious factor where buildings do not exceed 3 stories. It can cause annoying effects such as ponding or running of water across counter tops, tub decks, and so forth, and require periodic releveling of appliances and door jambs to keep them functioning properly. Tilts of less than 0.5% in floors are barely perceptible to most people and are considered a moderate degree of tilt to be induced by mine subsidence.

Tilt becomes much more important in tall or long structures and could require periodic jacking or leveling to regain acceptable conditions for situations where vertical and horizontal alignments are critical such as detailed machine and lathe work or silos, and water towers. Tilt can also increase or decrease gradients on gravity flow structures such as sewer lines or canals. This can progress beyond acceptable limits and in extreme cases may even reverse gradients resulting in serious problems that require substantial effort and expense to correct.

Curvature, which is the change in tilt for a given length, is important for two reasons. First, the curvature of the ground from subsidence is the process which generates the strains discussed above. Ground strains can be computed from measured values of curvature directly without any specific knowledge about the mine workings other than the depth. Second, curvature can induce large rotational stresses on the joints and unions of rigid, underground pipes and

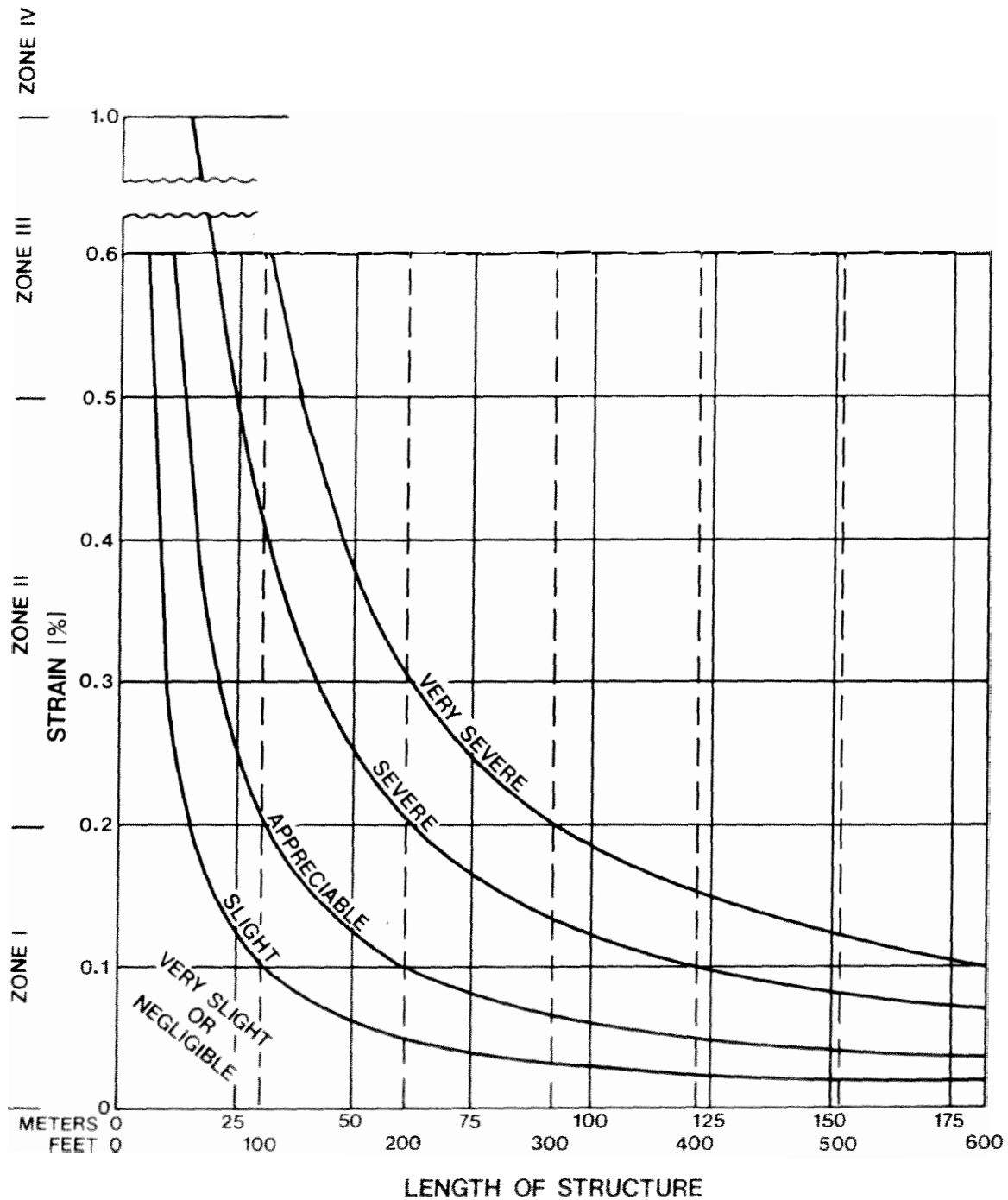

Figure 10. Relationship of damage to length of structure and horizontal ground strain and strain zones in Category 4 (See Table I.) (Modified from National Coal Board, Great Britain, and Baker, 1974).

Table 1. National Coal Board classification of mining damage (from National Coal Board, Great Britain, 1966).

Change of length of structure	Class of damage	Description of typical damage	Strain Zone
Up to 0.1 ft....	1. Very slight or negligible.	Hair cracks in plaster. Perhaps isolated slight fracture in the building, not visible on outside.	I
0.1 ft-0.2 ft...	2. Slight.....	Several slight fractures showing inside the building. Doors and windows may stick slightly. Repairs to decoration probably necessary.	II
0.2 ft-0.4 ft...	3. Appreciable...	Slight fracture showing on outside of building (or one main fracture). Doors and windows sticking; service pipes may fracture.	III
0.4 ft-0.6 ft...	4. Severe.....	Service pipes disrupted. Open fractures requiring rebonding and allowing weather into the structure. Window and door frames distorted; floors sloping noticeably; walls leaning or bulging noticeably. Some loss of bearing in beams. If compressive damage, overlapping of roof joints and lifting of brickwork with open horizontal fractures.	IV
More than 0.6 ft	5. Very severe...	As above, but worse, and requiring partial or complete rebuilding. Roof and floor beams lose bearing and need shoring up. Windows broken with distortion. Severe slopes on floors. If compressive damage, severe buckling and bulging of the roof and walls.	

Table 2. Categories of protection (from Brauner, 1973).

Category	Allowable tilt, $\times 10^{-3}$	Allowable strain, $\times 10^{-3}$	Explanation
I	2.5	1.5	Allowable are slight damages such as hair cracks in plaster.
II	5.0	3.0	Allowable are small reparable damages.
III	10.0	6.0	Allowable are damages that do not destroy the building or impair its service.
IV	15.0	9.0	Movements are such that completely reinforced structures are required to resist them.

conduits. Where curvature is expected to be significant, great care must be employed to ensure that pipe lengths and joints are designed and constructed to accommodate the rotational factors as well as the extensional and compressional changes.

Mitigation methods that address these factors are presented later in this report and several references are included in the selected references section as well. As one might expect, the greater the magnitudes of the subsidence-induced factors the more complex and radical the required mitigation techniques can become. Since the limiting consideration is usually horizontal ground strain, it is easiest to pick some value such as .005 (the lower limit of appreciable damage to structures with nominal dimensions of 50 feet) and seriously consider avoidance as the preferred alternative beyond that limit. Avoidance will also be discussed further in the following text.

Mine Shafts - One special case that has not been dealt with in any of the above discussion is the presence of shafts. Shafts, unless properly closed with engineered plugs, represent an extremely high risk associated with precipitous collapse and opening to great depths. Due to the potentially sudden nature of shaft collapse the risk includes serious personal hazard and life-threatening conditions as well as property damage or loss. Shaft-hazard classification and mitigation will be dealt with specifically in later sections of this report.

DRILLING AND GEOPHYSICAL INVESTIGATION

The drilling program for this investigation consisted of 97 holes totalling approximately 21,000 feet. The holes were drilled in a one month period during August and September of 1983 within an area of approximately three square miles (fig. 2 and Plate 1). The drilling contractor was Young Northern Exploration from Louisville, Colorado. Two Mayhew 1000-type rigs were used during the first three weeks of the program and drilling during the last week was performed with only one of the rigs. Geophysical logging was performed by Digilog Geophysical Service of Broomfield, Colorado.

Drill-hole locations were selected on the basis of the data portrayed on the nine maps and access restrictions on the surface. Many potential locations were dismissed due to interference such as housing, proximity to buried utilities, or valuable crops. The purpose of the drilling program was three

fold. 1) to acquire sufficient data about the mines in the Tri-Towns Area to analyze the present state of stability of the underground workings and verify location, depth and coal-extraction thickness; 2) to obtain representative logs and samples of the mined interval and the roof rock to assist in determining the amount of subsidence yet to occur in those areas where it has not gone to completion; and 3) to identify one or more small areas where the conditions were relatively uniform and amenable to additional drilling designed to develop an understanding of the density of drilling which might be required to evaluate or demonstrate the suitability of a specific tract of undermined land. Additionally, it was considered valuable to be able to compare the predicted results of subsidence potential on a given tract of land based on two significantly different drilling densities.

Geophysical logging of each bore hole was done because of its value for correcting time lag, sample mixing, identifying small but significant marker zones missed due to sampling methods, and general correlation between each hole and the other holes in the vicinity. It was anticipated that the caliper log could be used to identify and quantify zones of significant voids in the holes that penetrated the old workings. This was possible in most instances but could not be relied on to show all voids.

Three types of boreholes were drilled as part of this investigation. Full core holes were advanced when sound bedrock was encountered. These core holes (fig. 2 and Plate 1) and the accompanying geophysical logs provide the best and most reliable information in the study. They provide the subsurface control to which rotary holes and geophysical logs are tied. Spot coring was to be a major portion of the study. It was anticipated that distinct overburden intervals might be found throughout parts of the study area which would represent zones of specific strength or weakness. Spot coring in these intervals as well as in the coal seams was proposed in order to collect samples of the materials in these zones and determine the properties of the rocks to assist in subsidence modelling and prediction. Field analysis of the data revealed no laterally persistent zones on which drilling prognoses could be reliably made. Therefore, this portion of the drilling program was not conducted. Several spot cores of the coal in the mined interval were obtained using various combinations of drill bits and drilling procedures to evaluate their influence on recovery and core quality.

The majority of boreholes in the project area were high speed rotary holes logged lithologically by a project geologist at either 5-foot or 10-foot intervals and augmented with geophysical logs. In addition to lithology, rig behavior was observed to help identify zones of competent roof rock, rubble, void, and mine floors. Primary attention was focused on lost circulation of drilling fluid and whether or not it could be regained, penetration rate and drill string behavior such as free fall, penetration with or without weight on the drill string and with or without rotation. See Appendix A for representative logs.

Geophysical logs run in each hole consisted of natural-gamma, gamma-density, single point resistance and mechanical caliper. This combination of logs allow for easy discrimination among coals, clays and shales, and silts and sands.

The natural-gamma log measures in-situ radioactivity with a sensitive scintillation counter and is used to differentiate sedimentary rocks with organic materials from those without. Radioactive materials are usually concentrated in clays and shales because of the low permeability and their environment of deposition. Sandstones and coals display relatively low gamma counts.

High resolution gamma-density logs provide an indication of the relative density of the strata. Higher counts indicate less attenuation or lower density and usually indicate an organic type of material, such as coal. A radioactive source emits gamma signals into the rock and a scintillation counter reads the return signal.

Resistivity is measured using a single point resistance tool which actually measures the conductivity of the formation and its fluids. It is useful for differentiating between water-saturated material types since resistance values for organic zones and porous formations (sandstones) are usually higher than those of clays and clay shales.

Borehole diameter is measured using the mechanical caliper, a spring loaded arm attached to the probe. This tool is used to detect voids or washouts indicating weak zones in the formation. Large excursions on this log are indicative of open mining works (voids). The caliper log was primarily intended to quantify the size and degree of openness of voids encountered in the mined interval.

ANALYSIS OF THE DATA

Mine Features - Several analytical steps were performed on data from each hole. The first, which was done on every hole, was to predict, based upon the mine plan, what type of feature the bore hole should encounter at the mining level. The possibilities included: rooms, pillars, haulageways, and mine limits (areas beyond the rib). Evaluation of lithologic and geophysical logs and drill string behavior were used to determine what the actual conditions were and this was compared to the prediction in order to verify the accuracy of the mine maps. For example, if a pillar or area beyond the rib was predicted, confirmation would consist of: no erratic drill string behavior at the mined depth, no loss of circulation, recovery of sound coal in the return, good, in place coal indications on the geophysical logs and no significant caliper log deviations. Confirmation of a room would be erratic drill-string behavior with or without partial or complete loss of circulation, absence of sound coal in the return, absence of good coal picks on the geophysical logs with or without caliper-log variations.

The absence of coal, with little or no lost circulation, and a uniform caliper log was interpreted as indication that the "back was down." This means the roof of the mine has settled to the mine floor closing the void, and subsidence should be essentially complete.

Void Space - Lost circulation with caliper excursions indicates open rooms with rubble or collapsed roofs. The degree of openness was inferred from the nature of the lost circulation, i.e. partial or complete, recoverable with mud or not. Drill-string behavior was also used to evaluate the condition of the voids, i.e., freefall, settlement with or without rotation and/or weight of the string. The magnitude and length of open caliper readings were evaluated to arrive at a quantitative values for void space.

Caliper readings and the degree of openness were used to arrive at numerical values for the amount of remaining subsidence (S_r) that could be anticipated in various workings. Voids were classified as major or minor based on the ratio of indicated height of opening on the caliper log and the depth. The cutoff point for major versus minor voids was arbitrarily set at $.01h$ where h is the depth to the floor of the mine from the ground surface.

The analysis and classification of the drill-holes is depicted graphically on Plate 1.

Subsidence analysis and prediction

Surface Classification - In order to facilitate the subsidence analysis and prediction, the ground surface of the study area was divided into four categories based upon the information shown on the mine maps:

1. Areas not affected by undermining
2. Areas underlain by uniform room-and-pillar workings with pillars remaining representing approximately a 50% extraction ratio or less.
3. Areas underlain by random room-and-pillar workings or with pillars remaining representing approximately a 50% extraction ratio or greater.
4. Areas underlain by workings with few pillars remaining so as to approach total extraction.

Categories are shown on Plate 2.

Areas in Category 1 and 2 were not evaluated due to the unlikeliness of subsidence events. Category 2 areas could experience localized pothole subsidence or slow, progressive lowering with little or no significant ground strain due to pillar deterioration. There is no reasonable way to identify which areas may be more or less subject to either process. The only generalization that can be made is that shallower workings (less than 100 feet or so) have a greater potential to adversely affect the surface.

Areas in Category 3 represent the most complex situation and probably the worst potential for high ground strains and caving failures at the surface. Stress patterns may be fairly irregular and are probably beyond the ability of analytical techniques to reliably determine and portray in any meaningful way. Subsidence predictions in these areas should be based upon extremely detailed, site-specific investigations and a highly conservative analysis.

Areas in Category 4 are assumed to conform to the total extraction situation closely enough to allow reasonable predictions to be made on the basis of the profile functions outlined in the Subsidence Engineers Handbook of the British National Coal Board (NCB)(24).

Several factors need to be evaluated in order to demonstrate the applicability of this approach.

As discussed earlier, subsidence is affected by mining method and the properties of the overlying strata. This raises two very important questions: Is the effect significant? Does departure from the conditions for which the NCB model was derived cause conservative results?

Insight into the first question above can be gained by looking at the range of variation found in various coal fields where similar models have been developed and are being used. Most of the longwall mining has taken place in Europe and profile-function models have been used extensively. Comparative reviews of these models by others (5,31) show little variation in the primary factors from area to area even when substantial variations occur in the overburden. For example, the subsidence factor, said to be sensitive to lithological variations, varies from 0.70 to 0.90 throughout Europe. Areas with softer and younger rocks such as the Ruhr and Rhine districts in Germany exhibit higher values as do the British coalfields where the NCB model was derived.

Since Boulder-Weld coals occur in relatively soft, young sedimentary rocks the adoption of NCB values appears reasonable. Given that they are on the high end of the range the model should tend to produce conservative results if the actual parameters are not precisely correct for this area.

In response to the second question, comparison of the various profile functions indicates that the NCB curves are generally conservative as compared to the other models used in Europe. In fact HUD guidelines specify that in the absence of a demonstrable model for the area in question, NCB is the preferred model, and worst case values should be used (31).

The subsidence analysis performed for the various areas in category 4 were conducted compatibly with the HUD Guidelines for three reasons. First, the HUD

Guidelines represent a conservative, detailed, approach to the evaluation of subsidence hazard on a particular tract. Second the CGS concurs with the concept of a defensibly conservative approach with the option of demonstrating a better model when and where possible and applicable. Third, the general land use trends in the Tri-Town Area are oriented toward residential and light commercial growth. In all likelihood this will involve a great deal of HUD participation in the development of the area and to disregard their established guidelines would be unresponsive to the needs of the communities and, perhaps, even counterproductive.

Thus, the NCB model was determined to be valid and applicable to subsidence analysis in Category 4 areas of the Tri-Towns.

Subsidence Determination - As mentioned earlier, the first and critical step in the process is to determine S_{max} . Because drilling evidence indicated that some of the subsidence had already taken place it was decided that a more appropriate value, S_r (remaining subsidence) should be used instead. As the profile functions conform to the principle of superposition, this should introduce little or no error into the analytical procedure. S_r was discussed briefly earlier in the report as being a function of the degree of openness of voids encountered and the height of the open zone as indicated on the caliper logs. The actual numerical values used for subsidence profiling were arrived at by the following method (fig. 11).

Caliper log excursions in the region of the mined interval were evaluated and divided into three zones -- less than 6 inches, greater than 6 inches, greater than 8 inches. The aggregate height of the zones greater than 6 inches and greater than 8 inches were measured. The zone less than 6 inches was not assumed to represent any significant potential for openness as the nominal diameter of the bore hole was 5 1/8 inches. Based upon subsidence factor data for various methods of stowing the goaf (3,5), 25% of the height greater than 6 inches and 50% of the height greater than 8" were summed to arrive at S_r . Depth to the floor was noted from the geophysical logs as well. Lines of profile were drawn through representative parts of mines in Category 4 Areas. All boreholes which penetrated voids in the vicinity of each line of profile were evaluated and representative values of S_r and h were assigned to the profiles. Values for the width of the panels were measured from the plot of the profile through the workings (fig 12). These three values-- S_r , h and w --were

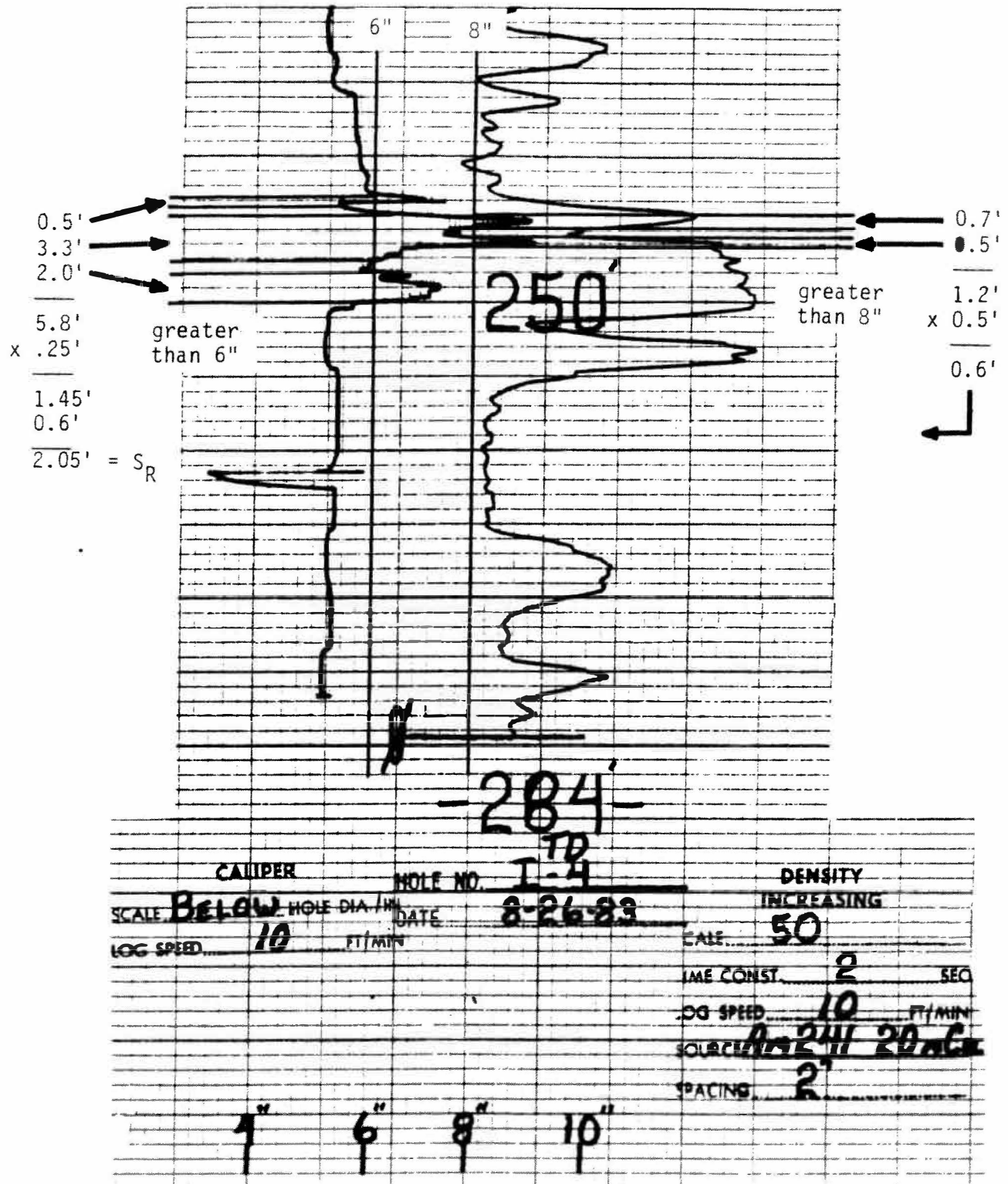

Figure 11. Determination of remaining subsidence (S_R).

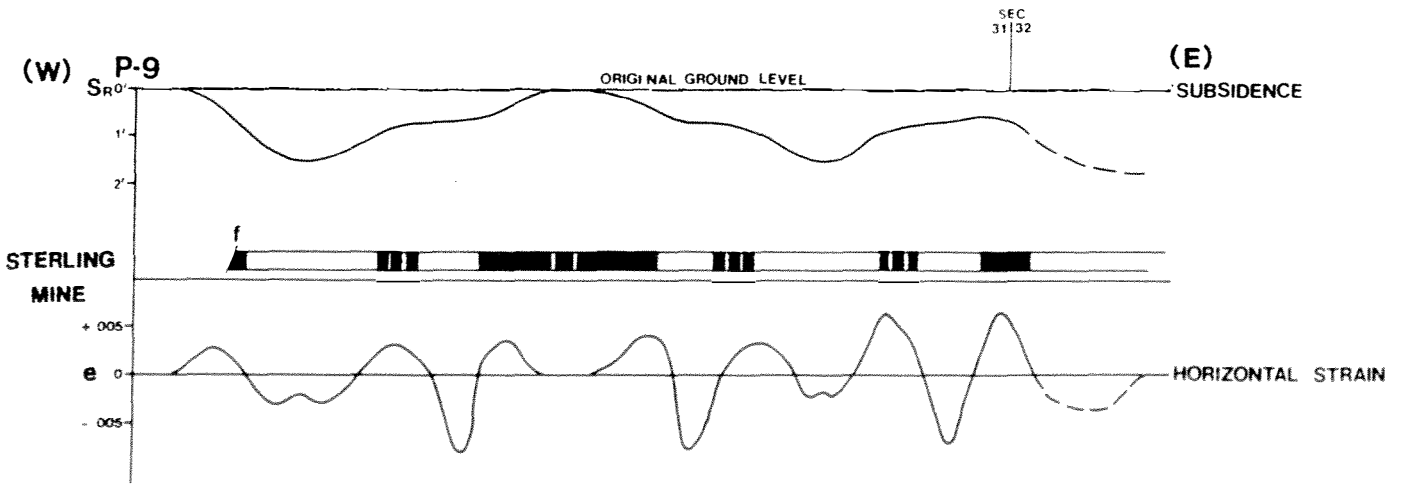
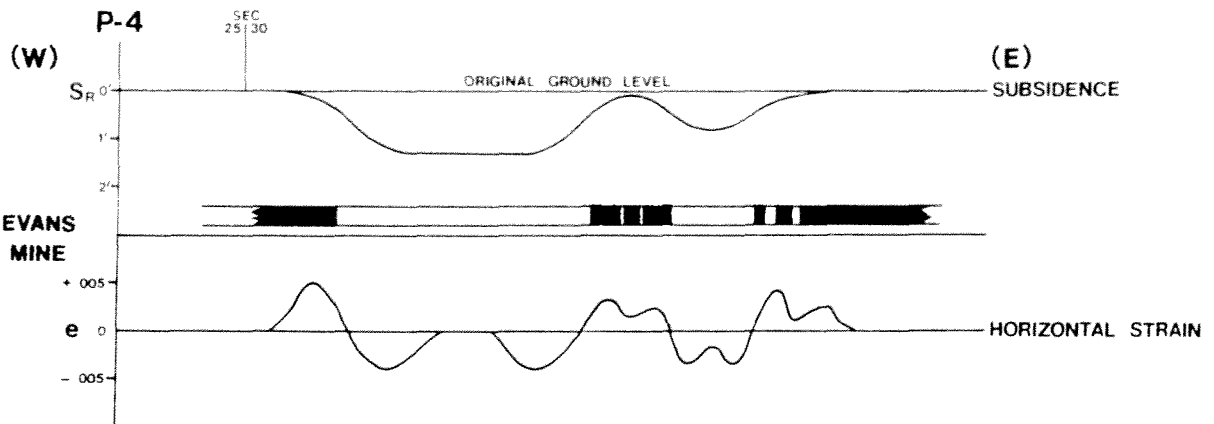

Figure 12. Representative subsidence profiles.

used to determine the surface subsidence and the horizontal strain using tables and graphs in the Subsidence Engineers Handbook, (such as fig. 13 and Table 3).

Ground Strain Zones - Vertical displacement data were posted on a map of the study area (Plate 2) and contoured at 1-foot intervals. Ground-strain zones were determined and extrapolated over adjacent mine areas where the conditions were determined by inspection and comparison to be similar to those along the line of profile. These zones are not continuous due to the presence of intervening areas which are in Categories 2 and 3. Ground strain values were divided into four zones based upon the anticipated severity of damage to a residential structure with a nominal dimension of 50 feet (fig. 10 and Tables 1 and 2). Some generalizing and smoothing of the strain data was done to make the zones realistic and mappable. These zones were then posted on the subsidence map. Limits for the ground-strain zones were based upon the following numerical values (fig. 10 and Table 1).

Zone I -- strains less than 0.002

Conforms to the very slight or negligible category.

Zone II -- 0.002 to 0.005 Conforms to the slight category.

Zone III -- 0.005 to 0.01 Conforms to the appreciable category.

Zone IV -- Strains greater than 0.01 and areas around shafts -- Conforms to the severe category.

See fig 8 and tables 1 and 2 for a description of the types of damage associated with each category.

Traces of vertical subsidence and horizontal strain are shown above and below the workings profile for each line in Appendix B.

Shafts - Mine shafts are a special case. Unless it can be shown that they were closed with an engineered plug or cap, it should be assumed that they were not properly sealed and represent a serious, potentially life threatening situation (4). For the purposes of this study an area of Category 4, Zone IV associated with each shaft is defined by a circle of radius equal to the depth of the shaft. This represents an angle of 45° from the bottom of the shaft to the surface. The extra caution associated with this rather wide zone at the surface is due to several factors: 1) The precise location of the shaft may

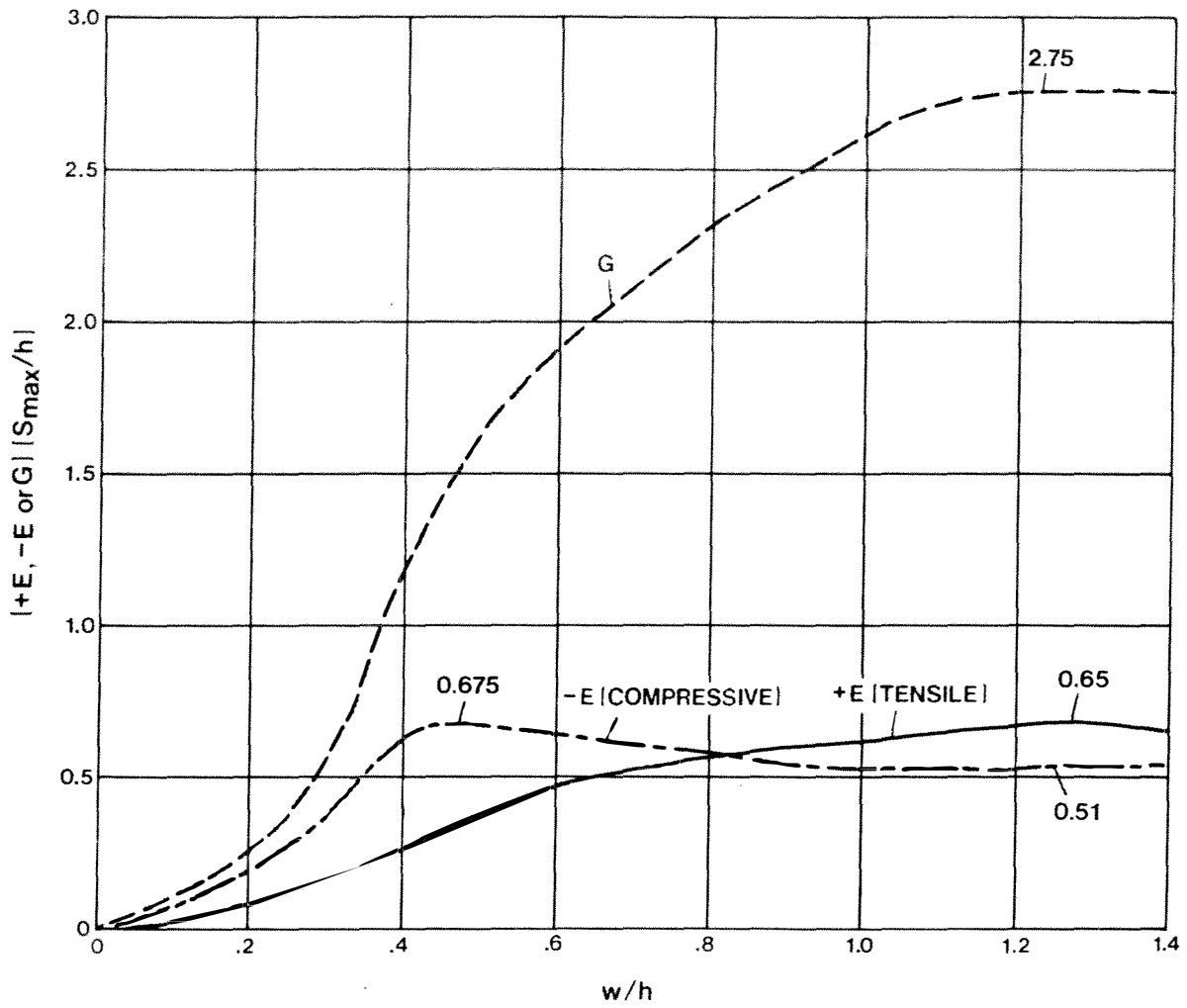

Figure 13. Maximum values of slope and strains for critical and subcritical profiles (from Yokel, Salomone, and Chung, 1971).

Table 3. Relationships for various strain values in a subsidence profile (from National Coal Board, Great Britain, 1975).

Values of e/E	Extension (+E)								Compression (-E)									
	0	0.20	0.40	0.60	0.80	1.00	0.80	0	0.20	0.40	0.60	0.80	1.00	0.80	0.60	0.40	0.20	0
w/h RATIO OF PANEL	DISTANCES FROM PANEL CENTRE IN TERMS OF DEPTH																	
3.0	2.2	1.78	1.67	1.61	1.56	1.50	1.46	1.36	1.34	1.31	1.28	1.25	1.19	1.10	1.03	0.96	0.90	0.70
2.6	2.0	1.58	1.47	1.41	1.36	1.30	1.26	1.16	1.14	1.11	1.08	1.05	0.99	0.90	0.83	0.77	0.70	0.50
2.2	1.8	1.38	1.27	1.21	1.15	1.10	1.06	0.96	0.94	0.91	0.88	0.85	0.79	0.70	0.63	0.57	0.50	0.30
2.0	1.7	1.28	1.17	1.11	1.05	1.00	0.96	0.86	0.84	0.81	0.78	0.75	0.69	0.60	0.53	0.47	0.40	0.20
1.8	1.6	1.17	1.07	1.01	0.95	0.90	0.86	0.76	0.73	0.71	0.68	0.65	0.59	0.50	0.43	0.37	0.30	0.10
1.6	1.5	1.08	0.97	0.91	0.85	0.80	0.76	0.66	0.63	0.61	0.58	0.55	0.49	0.40	0.33	0.27	0.20	0.03
1.4	1.4	0.98	0.87	0.81	0.75	0.70	0.66	0.56	0.53	0.51	0.48	0.45	0.39	0.30	0.23	0.17	0.10	0
1.3	1.35	0.93	0.82	0.76	0.70	0.65	0.61	0.51	0.49	0.46	0.43	0.40	0.34	0.25	0.18	0.12	0.05	0
1.2	1.3	0.88	0.77	0.71	0.66	0.61	0.56	0.46	0.44	0.41	0.38	0.35	0.29	0.20	0.13	0.07	0.02	0
1.1	1.25	0.83	0.72	0.66	0.61	0.56	0.52	0.42	0.39	0.37	0.33	0.31	0.24	0.15	0.09	0.03	0	0
1.0	1.2	0.79	0.68	0.62	0.57	0.51	0.47	0.37	0.35	0.32	0.29	0.26	0.20	0.10	0.05	0	0	0
0.98	1.19	0.78	0.67	0.61	0.56	0.50	0.46	0.36	0.34	0.31	0.28	0.25	0.19	0.09	0.04	0	0	0
0.96	1.18	0.77	0.66	0.60	0.55	0.49	0.45	0.35	0.33	0.30	0.27	0.24	0.18	0.09	0.04	0	0	0
0.94	1.17	0.76	0.65	0.59	0.54	0.48	0.44	0.35	0.32	0.30	0.26	0.23	0.17	0.08	0.03	0	0	0
0.92	1.16	0.75	0.64	0.58	0.53	0.47	0.43	0.34	0.31	0.29	0.25	0.22	0.16	0.07	0.02	0	0	0
0.90	1.15	0.74	0.63	0.57	0.52	0.46	0.42	0.33	0.30	0.28	0.24	0.21	0.15	0.06	0.02	0	0	0
0.88	1.14	0.73	0.62	0.56	0.51	0.46	0.41	0.32	0.29	0.27	0.24	0.21	0.15	0.05	0.01	0	0	0
0.86	1.13	0.72	0.61	0.55	0.50	0.45	0.40	0.31	0.29	0.26	0.23	0.20	0.14	0.05	0	0	0	0
0.84	1.12	0.71	0.60	0.54	0.49	0.44	0.39	0.30	0.28	0.25	0.22	0.19	0.13	0.04	0	0	0	0
0.82	1.11	0.70	0.59	0.53	0.48	0.43	0.38	0.29	0.27	0.25	0.21	0.18	0.12	0.03	0	0	0	0
0.80	1.10	0.69	0.58	0.53	0.48	0.42	0.37	0.29	0.26	0.24	0.20	0.17	0.11	0.02	0	0	0	0
0.78	1.09	0.68	0.57	0.52	0.47	0.41	0.36	0.28	0.26	0.23	0.20	0.17	0.11	0.02	0	0	0	0
0.76	1.08	0.67	0.57	0.51	0.46	0.40	0.36	0.27	0.25	0.22	0.19	0.16	0.10	0.01	0	0	0	0
0.74	1.07	0.67	0.56	0.50	0.45	0.39	0.35	0.26	0.24	0.22	0.18	0.15	0.09	0.01	0	0	0	0
0.72	1.06	0.66	0.55	0.49	0.44	0.38	0.34	0.26	0.24	0.21	0.17	0.15	0.09	0	0	0	0	0
0.70	1.05	0.65	0.54	0.48	0.44	0.37	0.33	0.25	0.23	0.20	0.17	0.14	0.08	0	0	0	0	0
0.68	1.04	0.64	0.54	0.47	0.43	0.37	0.32	0.24	0.22	0.20	0.16	0.13	0.07	0	0	0	0	0
0.66	1.03	0.64	0.53	0.47	0.42	0.36	0.31	0.24	0.22	0.19	0.16	0.13	0.07	0	0	0	0	0
0.64	1.02	0.63	0.53	0.46	0.41	0.35	0.31	0.23	0.21	0.19	0.15	0.12	0.06	0	0	0	0	0
0.62	1.01	0.63	0.52	0.45	0.41	0.34	0.30	0.23	0.21	0.18	0.15	0.12	0.05	0	0	0	0	0
0.60	1.00	0.62	0.52	0.45	0.40	0.34	0.29	0.22	0.20	0.18	0.14	0.11	0.05	0	0	0	0	0
0.58	0.99	0.62	0.51	0.44	0.39	0.33	0.29	0.22	0.19	0.17	0.14	0.10	0.04	0	0	0	0	0
0.56	0.98	0.61	0.51	0.44	0.39	0.33	0.28	0.22	0.19	0.17	0.13	0.10	0.03	0	0	0	0	0
0.54	0.97	0.61	0.51	0.43	0.39	0.32	0.28	0.21	0.19	0.16	0.13	0.09	0.03	0	0	0	0	0
0.52	0.96	0.60	0.51	0.43	0.38	0.32	0.27	0.21	0.18	0.16	0.12	0.09	0.02	0	0	0	0	0
0.50	0.95	0.60	0.51	0.43	0.38	0.32	0.27	0.21	0.18	0.16	0.12	0.08	0.02	0	0	0	0	0
0.48	0.94	0.60	0.51	0.43	0.38	0.31	0.27	0.20	0.18	0.15	0.12	0.08	0.01	0	0	0	0	0
0.46	0.93	0.60	0.51	0.43	0.38	0.31	0.27	0.20	0.18	0.15	0.11	0.08	0.01	0	0	0	0	0
0.44	0.92	0.60	0.51	0.43	0.39	0.31	0.27	0.20	0.18	0.15	0.11	0.07	0.01	0	0	0	0	0
0.42	0.91	0.60	0.51	0.44	0.39	0.31	0.27	0.20	0.18	0.15	0.11	0.07	0	0	0	0	0	0
0.40	0.90	0.61	0.52	0.45	0.40	0.32	0.28	0.21	0.18	0.15	0.11	0.07	0	0	0	0	0	0
0.38	0.89	0.61	0.53	0.45	0.41	0.32	0.28	0.21	0.18	0.15	0.11	0.07	0	0	0	0	0	0
0.36	0.88	0.62	0.53	0.46	0.42	0.33	0.29	0.21	0.18	0.15	0.11	0.07	0	0	0	0	0	0
0.34	0.87	0.62	0.54	0.48	0.43	0.34	0.30	0.22	0.19	0.15	0.11	0.07	0	0	0	0	0	0
0.32	0.86	0.63	0.55	0.49	0.45	0.35	0.30	0.22	0.19	0.16	0.12	0.08	0	0	0	0	0	0
0.30	0.85	0.65	0.57	0.51	0.47	0.37	0.32	0.23	0.20	0.16	0.12	0.08	0	0	0	0	0	0
0.28	0.84	0.66	0.58	0.54	0.49	0.39	0.33	0.24	0.21	0.17	0.13	0.08	0	0	0	0	0	0
0.26	0.83	0.68	0.60	0.57	0.51	0.41	0.35	0.26	0.22	0.18	0.14	0.09	0	0	0	0	0	0
0.24	0.82	0.70	0.63	0.60	0.54	0.44	0.37	0.28	0.23	0.20	0.15	0.10	0	0	0	0	0	0
0.22	0.81	0.72	0.66	0.63	0.58	0.47	0.39	0.30	0.25	0.21	0.16	0.11	0	0	0	0	0	0
0.20	0.80	0.74	0.69	0.66	0.61	0.49	0.42	0.32	0.27	0.23	0.18	0.12	0	0	0	0	0	0

be different than the posted location on the map. 2) Shafts represent actual openings to the surface and as such instability and failure in any given direction can approach a 1:1 ratio in the unsupported walls. 3) Shafts present a significant opportunity for diversion of shallow subsurface water into the mine workings with flow rates high enough to cause piping and erosion failures at the surface some distance from the actual shaft.

It should be noted that the zones portrayed on Plate 2 represent general conditions of the area, as determined by the level of investigation, the density of drilling, and the conditions indicated on the mine map. More detailed investigations may show conditions to be other than indicated on Plate 2. A recommendation made later in this report is for site-specific investigation in advance of new development or redevelopment on all properties in Zones II, III, or IV of Category 4 as well as Categories 2 and 3. This will allow for possible detailed reclassification of any given tract if it is deemed that such further study is desirable.

More detailed drilling

An attempt was made to more closely define the density of drilling that might be required to accurately portray the situation on a relatively small (5 to 10 acre) tract. Two candidate areas were selected on the basis of the low density drilling program, the indicated conditions on the mine plan, and the fact that they were undeveloped, allowing total flexibility in drill-hole location. Only one of these areas was drilled at a greater density due to budgetary considerations (Plate 1).

It was hoped that variations in conditions in the mine due to the degree and uniformity of remaining pillars would be discovered with a site-specific, detailed drilling program. A nominal density of one hole per acre was selected and seven additional holes were drilled to augment the data of two previously drilled holes on a 7 to 8 acre tract. The additional holes were located so as to penetrate rooms, pillars, and haulageways beneath the area.

Results from the additional drilling indicated that the back was down throughout the area regardless of the type of feature drilled. No additional interpretation was necessary or possible. It does appear, however, that a nominal drilling density of one hole per acre with each hole specifically

located to intercept and interpret a particular mine feature is adequate to evaluate an undeveloped piece of ground to determine the subsidence hazard associated with it.

LAND USE CONSIDERATIONS

Land use patterns and the changes in them are the driving force behind hazard analyses of most kinds. Just as an avalanche or rockfall episode that occurs in an unoccupied mountain valley presents no "hazard," a subsidence event in the middle of an unoccupied wheat field also presents no hazard. Implicit in the designation of a hazard is the notion of loss. This potential for loss may be in the form of property or bodily injury. The evaluation of the potential for loss due to a geologic phenomenon such as mine subsidence becomes a question of risk assesment and risk avoidance.

For example, the risk associated with subsidence on an undeveloped tract of agricultural land in the Tri-Towns Area is a function of the probability of occurrence, the magnitude of the event, and the degree of damage or disruption caused. One can easily see that although the probability and magnitude may be substantial, the risk may be considered acceptable because the loss is small. This means that the question of probability and magnitude are rendered insignificant by the low risk.

Consider the same field with 100 homes built on it. With an assumed average value of \$60,000 per home, 4 persons per home, furniture, automobiles, and utilities the same questions of probability and magnitude assume completely different proportions. Thus, a need arises for planning to identify the optimum uses for each tract of land and foster appropriate development based upon the hazard to preclude escalation of risk to unacceptable levels.

As the development pressure in the Tri-Towns Area increases due to growth and population influx, much of the undermined agricultural land presently at low risk will be converted to residential and industrial land with concomitantly higher levels of risk to the improvements and occupants.

Great care, planning, and effort should go into the process of determining which land is suited for which use. Many factors will be important to the ultimate decisions and one of these should be the potential for mine subsidence.

In some cases the risk may be acceptable; in others the value of the land and its intended purpose will justify the cost of certain mitigation actions, and in still others the risk or cost of mitigation may be considered intolerable. Only through the collection and evaluation of sufficiently detailed data can these decisions be made reliably and realistically.

To that end, all undermined areas as shown on Plate 2 with the exception of Category 4, Zone I should require detailed subsidence investigations prior to zoning changes or preliminary platting. All investigations should meet the minimum criteria found in HUD's Construction of Housing in Mine Subsidence Areas (31), and should be conducted by qualified professional personnel with demonstrated experience in the field of mine subsidence evaluation.

Mitigation Measures

Mitigation measures can generally be divided into three categories: remedial action, protective measures, and avoidance. It is important to distinguish between mitigation of the effect, subsidence hazard, and correction of the cause, underground voids associated with previous mining activity. It is rarely economical to correct the source, i.e., fill the voids, unless the mining is so close to the surface as to make it accessible with conventional surface-excavation equipment. This puts the practical limit of such activity at 50 feet or less. While deep backfilling projects have been conducted with varying degrees of success, the costs have always been high, positive results are far from guaranteed, and in some cases, onset or intensification of subsidence appears to have been induced by backfilling activities.

Presently Developed Areas - Remedial and repair programs are obviously suited to areas where development has already occurred and the improved value of the area is sufficient to justify the expense and effort.

Retrofit and Reconstruction - Many areas shown to be subject to significant vertical subsidence and horizontal ground strain in this area are already developed. As such they represent a considerable investment in personal property value and facilities. Without detailed, site-specific analysis it is not possible to predict the nature of the hazard in these areas or the time interval in which subsidence is likely to occur. Given this situation,

wholesale retrofit or reconstruction of neighborhoods is probably not cost effective or justified. Recent studies in Great Britain indicate that even though an entire area undergoes subsidence, only about half the structures in the area can be expected to manifest any significant degree of damage (15). Little is known as to why only some structures are adversely affected while other, similar ones in the same area and theoretically subject to the same stresses are not.

The solution to this dilemma is not close at hand even where the subsidence phenomenon is fairly well understood. However, certain steps can be taken to minimize the potential damage and threat to life and limb in areas where the predicted subsidence is in the appreciable or severe categories (Category 4, Zones III and IV).

Generally it is advisable that residents and workers in subsidence-prone areas be educated regarding the nature and visible manifestations of subsidence damage and be made familiar with appropriate courses of action for dealing with certain problems. This could be accomplished through publicly sponsored workshops or presentations at town meetings. Articles in local newspapers can also help familiarize residents with the common problems and solutions in subsidence-prone areas.

As infrastructure is routinely replaced, it can be upgraded to accommodate and/or withstand the anticipated effects of subsidence. Underground gas line leaks probably represent the greatest hazard to the public in the area. Positive outdoor ventilation of gas-line trenches can be easily achieved and can significantly reduce the likelihood of reaching explosive gas concentrations. All structures serviced by underground gas lines in areas of anticipated appreciable or severe strain (Categories 3 and 4, Zone IV) should be evaluated to assure external gas-line venting at the foundation penetration.

New Development - Where the ground strains are low as in Category 4, Zone II, and vertical subsidence is tolerable, structural modifications can be incorporated into new structures so that they can either withstand or accommodate the anticipated strains. This would typically involve some additional design and construction costs but these should not be prohibitive in most cases.

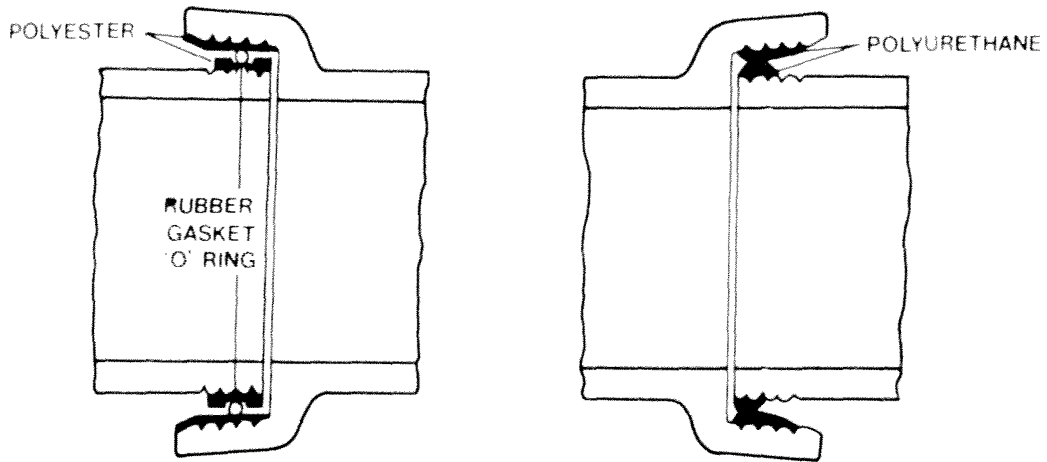

a) Spigot and socket joint with O ring

b) Spigot and socket joint of polyurethane

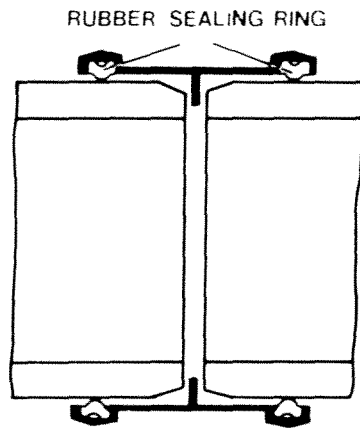

c) Sleeve joint

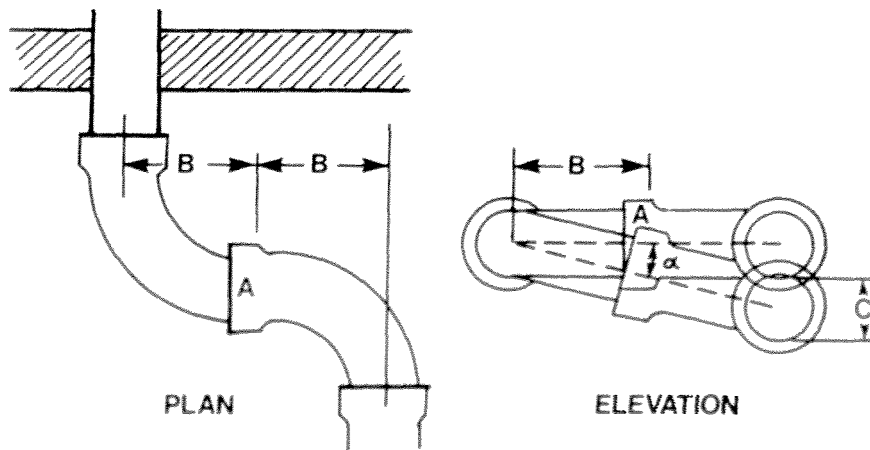

d) Swivelling joint with two right-angle bends

Figure 14. Flexible joints (modified from Orchard, 1972).

The most cost effective method of doing this for residential structures and small, commercial or light industrial buildings is to reinforce the foundation of the structure and isolate it from the in-place soil with a friable layer such as 6 to 8 inches of clean sand. It is also of some benefit to make the superstructure more flexible and to construct wider than normal framing tolerances for doors and windows. Construction and reconstruction should be performed so as to allow releveled or jacking if necessary.

Utility connections should be flexible as well and should be designed to accommodate the strain, dislocation, and tilt and curvature calculated at a given site (25). More detailed information on design measures suitable for various types of construction can be obtained from several of the sources noted in the Selected References Section (3,5,25).

Shaft Hazard Mitigation - Shaft hazard mitigation can be divided into two types of activities. Accurate location and determination of the physical condition of the shaft and plug (if any) will, in most cases, allow for a substantial reduction in the size of the area adversely affected by the presence of the shaft. The second type of shaft mitigation will include actual engineering design and construction of abandonment plugging and filling works. Such designs should be based upon site-specific conditions at the shaft location and the proposed surface use. This will require excavation and probably drilling of the shaft to accurately evaluate the conditions of the backfill and current plug materials. The reader is referred to Bell, 1975 (4) for further specific information on shaft closure.

Avoidance - As strain values increase into the appreciable and severe ranges the avoidance options on undeveloped land become increasingly worthy of consideration. There are risks associated with any use of land. However, if the subsidence prediction does not include ground rupture or pothole caving, there would be essentially no personal hazard associated with parkland- or greenbelt-type uses. The absence or minimal development of structures or utilities substantially reduces the risk as was discussed previously in the analysis of farmland versus residential subdivision.

Avoidance has additional advantage in that, if significant subsidence is predicted for an area, it can be monitored easily and the subsidence can be documented when it occurs. This will then allow uses compatible with

subsidence predictions and also allow the collection and analysis of surficial data to help understand the subsidence phenomenon better in adjacent areas.

CONCLUSIONS AND RECOMMENDATIONS

Conclusions - Much of the Tri-Towns Area is underlain by abandoned coal mines of the Boulder-Weld coal field. The type of mining employed in the field was room-and-pillar mining with pillar extraction at varying levels of completeness occurring during retreat from the headings in the mines.

Subsidence associated with the voids left after mining has and will continue to adversely affect the ground surface over and adjacent to the mines. The type and degree of development activity, past and future, plays a large role in determining the potential loss related to a given subsidence episode.

The ground surface in the study area can be divided into four categories related to subsidence potential, its patterns, and possible effects:

1. Beyond the limits of mine influence and no hazard.
2. Undermined by room-and-pillar workings with pillars remaining in uniform distribution patterns representing a 50% extraction ratio or less. This area is subject to some probability of caving and "pot-hole" type failures at the surface where the mines are relatively shallow (less than 100 feet).
3. Undermined with room-and-pillar workings with pillars remaining in random distribution patterns or extraction ratios greater than 50%. Without extremely detailed subsurface investigations showing otherwise, these must be assumed to be subject to both caving and trough-like subsidence in complex and indeterminate patterns.
4. Underlain by room-and-pillar working with essentially all pillars pulled so as to approximate total extraction and render the area amenable to trough-subsidence analysis using the methodology developed by the National Coal Board (NCB) of Great Britain.

Category 4 is further divided into four zones based on the values of horizontal ground strain predicted by the NCB Model and the degree of damage that could be anticipated to a residential structure with a nominal long dimension of 50 feet.

- I. Strains less than 0.002 - very slight or negligible damage.
- II. Strains greater than 0.002 but less than 0.005 - slight damage.
- III. Strains greater than 0.005 but less than 0.01 - appreciable damage.
- IV. Strains greater than 0.01, and areas around shafts - severe damage.

See fig. 10 and Tables 1 and 2 for descriptions of the anticipated damage classes above.

Mitigation measures including structural modifications to existing structures and engineering works such as pipe lines, roadways and irrigation ditches and incorporation of mitigation design features into new construction in areas of potentially negligible-to-slight subsidence damage (Category 4, Zones I and II) are economically feasible and can significantly reduce the potential for future damage or personal hazard. As the degree and complexity of mitigation measures increase to deal with potentially appreciable-to-severe damage (Category 4, Zones III and IV) the costs and margins for error are such that avoidance becomes the preferred alternative for undeveloped land. Where development has already occurred and the improved land value is relatively high, subsidence mitigation for specific high hazards, such as gas-line failure, should be seriously considered. Structural modifications to existing buildings and facilities should be evaluated on a case-by-case basis.

Recommendations

1. Areas not subject to subsidence (Category 1) or subject to only negligible damage (Category 4, Zone I) can be developed without further subsidence investigation or special subsidence mitigation measures.

2. Areas subject to slight subsidence damage (Category 4, Zone II) can be developed if suitable subsidence-mitigation measures are incorporated into the design of structures and utilities. The specific mitigation conditions should be based upon detailed, site-specific subsidence investigations. Mitigation measures for reconstruction, renovation, or substantial remodeling of existing structures should be based upon detailed, site-specific subsidence evaluation or conservative estimation of the values of future subsidence, strain, tilt, and curvature.
3. Areas subject to potential caving failures and random, localized, potentially appreciable or severe ground strains (Categories 2, 3, and Category 4-Zones III and IV) should be subject to detailed, site-specific subsidence investigations prior to any new construction, reconstruction, or substantial structural modification to existing structures. Additionally, as buried utilities are routinely upgraded, they should be designed to accommodate or withstand the predicted levels of strain, tilt, and curvature derived from detailed subsidence evaluation or conservative estimation.
4. All subsidence investigations should contain, as a minimum, the data and details found in the HUD Guidelines (31) and should be prepared by qualified professionals with experience in mine subsidence evaluation. Reports of these investigations should be submitted to the Colorado Geological Survey for review and comment as provided for in CRS 24-65.1-101 et seq., prior to final approval by any authorized local, county, state, or federal agency.
5. Public information and education programs should be instituted for officials and residents of the Tri-Towns Area to familiarize them with the mechanics of the subsidence process and assist them in identification and mitigation of subsidence damage and/or hazards.

ESSENTIAL COMPONENTS OF A COMMUNITY-WIDE SUBSIDENCE INVESTIGATION

One of the original objectives of this project was to use it as a prototype to obtain insight into techniques applicable to other, similar studies throughout the undermined areas of Colorado. While formal guidelines are not appropriate at this stage, several observations and recommendations can be made to assist future investigations of the same general type.

1. Prior to developing a drilling program, the mine maps for the area should be reviewed and compared to determine the location of representative areas and trends such as depth to mining, time of activity, etc. This preliminary information can be most helpful in designing a drilling program that will efficiently address as many of the subsidence related questions as possible.
2. Accurate orientation of mine plans and maps of surface features to the same control points and to each other is essential to a successful study. All data should be plotted to a common, scale such as 1:2,400. This is the most frequently used scale for coal-mine maps and is sufficiently large to accurately locate drill-hole sites. In many instances surveying may not be necessary to locate drill holes. However, minimum accuracy requirements should be established and appropriate stationing procedures used. Chain-and-Brunton compass methods from field-verified control points appear to be suitable for the level of accuracy needed in a community-wide study.
3. Drill-hole density and location relative to particular mine features and other drill holes of the study are very important considerations in subsidence investigations. Balance needs to be achieved between acquiring sufficiently detailed information to characterize the mines to the desired degree and the cost associated with subsurface investigations. If prior drilling data is available in the area, it should be evaluated to determine if it can be incorporated into study as well. The site-specific nature of any drilling program generally precludes using rules-of-thumb. The investigation of the Tri-Town Area consisted of 97 holes distributed throughout an area of approximately 2.5 square miles of which about two thirds is undermined. This represents a drill hole density of just less than one hole per 10 acres.

The more detailed study conducted in the northwest corner of Frederick consisted of nine holes on a tract of between 7- to 8-acre, achieving a density of just over one hole per acre.

In both of the above cases the density used was considered adequate for the specific level of the investigation undertaken. Drill-hole spacing equivalent to those in this community study could be used for the preliminary planning and costing phases of developing a similar community-wide study. However, in a different area it is quite likely that the unique character of the mining and surface development (existing or proposed) could require large variations in order to develop the level of detail needed for a particular area of interest. The less uniform the conditions being evaluated are in the area of interest, the greater the required drilling density will be.

4. Drill-hole location becomes more complex and critical when the study takes place in an already developed area. Great care must be taken to ensure that the subsurface investigation does not damage or endanger the buried utilities in the area, especially water and gas lines. A careful review of mine plans should allow the investigator to choose alternative drilling sites when the presence of critical underground structures or overhead electrical lines precludes a given hole location.

5. Rotary drilling and lithologic logging augmented by down hole geophysical surveys appear to provide the most usable data for the lowest total cost per foot. The use of the geophysics to actually pick the lithologic changes makes sampling at 10-foot intervals plus noting pronounced changes (i.e. coals, water table, hard sandstones) more than adequate. An important aspect of maximizing the retrieval of pertinent drilling data is the continuous observation of drill-rig and drill-string behavior by an experienced professional to ascertain the physical conditions of the strata in general and the mined interval and immediate roof rock in particular.

6. A vicinity investigation should incorporate at least one full core hole with an accompanying suite of geophysical logs. This assists considerably in correlation, comparison, and analysis of the other subsurface information. Spot coring in the coal seam can help arrive at a quantitative analysis of the pillar strength by collecting samples and performing rock mechanics testing.

If significant horizons can be forecast in the roof rock, such as competent sandstones of regional extent, they too should be sampled and tested.

Coring through highly variable strata such as the mudstones, soft sandstones, and coals of the Laramie Formation can be problematical. The principal considerations are to achieve a satisfactory penetration rate and yet recover a high percentage of quality core. If coring is commenced in a mudstone two feet above a selected coal horizon, hours may be lost. Additionally the bit may be fouled with the mud and clay so that even when the coal is reached, poor core is obtained.

Several techniques were evaluated during this investigation to find a satisfactory method of obtaining good spot core results. The following method proved to be the most successful.

The hole in which spot coring was to take place was identified and all adjacent holes were drilled before coring it. Based upon data from adjacent holes, the spot core interval was selected and rotary drilling proceeded to within 5 feet of the top of the core zone. At this point circulation (pumping mud and rotating the bit without drilling farther) is carried out until the return flow is free from drilling chips. This usually takes several minutes at 200 to 300 feet. The hole is then drilled two 2 more feet, samples are taken and the hole is circulated again. The hole is then advanced in one 1-foot intervals and circulated until the desired lithology is found in the return flow. At that point, the predetermined spot core interval is cored.

For coal coring, a diamond bit with moderate rotation and moderate fluid flow combined with fairly short runs, approximately 5 feet, produced the best core. For competent sandstones, carbide bits with high rotation and moderate fluid flows produced the best core. Run length did not seem to have any appreciable effect on the recoverability or quality of the sandstone cores.

7. Additional coring should be carefully evaluated on a case by case basis. In the Tri-Towns Study coring was about the fifteen times more costly per foot than rotary drilling. In most cases, once a representative full core has been acquired, it would probably be more cost-beneficial to have fifteen more rotary holes and logs than additional core.

8. Drilling prognoses should always be made, both for the depth to the mined interval and the anticipated mine feature to be encountered. Comparison between the expected and actual conditions is essential for determining the accuracy and validity of the mine plan. Comparison of the agreement or lack of agreement between predictions and actual results can be very valuable to prove or adjust the mine location and orientation with respect to the ground surface.

In summary, a community-wide approach to evaluating subsidence hazards through a moderately-detailed study such as this one offers several advantages but has limitations which must also be recognized. A major advantage is the ability to lay out a drilling program designed to answer certain questions that are critical to evaluating general problems rather than just the conditions at a specific location as is the case in site-specific investigations. This more general approach allows the technical investigator to make fairly definitive conclusions concerning the relative hazard of certain parts of the undermined area. The major limitation of this approach is that there are other parts of the area that are not amenable to any recognized analytical method and thus remain unevaluated even though it is probable that they include moderate to high subsidence potential. Such areas will still require detailed site by site investigations if the hazard is to be properly evaluated.

However, both the hazard evaluation and the delineation of areas too complex or poorly known for a general analysis can provide information that is extremely valuable to either public officials or private sector developers in guiding new or redevelopment planning in a way that minimizes costs and future risk to area residents.

SELECTED REFERENCES

1. Amuedo and Ivey, 1975, Coal Mine Subsidence and Land Use in the Boulder-Weld Coalfield, Boulder and Weld Counties, Colorado: Colorado Geological Survey Environmental Geology No. 9, 63 p.
2. Babcock, S.D., 1973, Undermining as an element in land use planning (M.S. Thesis): Southern Illinois Univ., Edwardsville, 84 p.
3. Baker, Michael, Jr., 1974, Architectural measures to minimize subsidence damage, NTIS PB 242 466.
4. Bell, F.G., 1975 Site Investigations in Areas of Mining Subsidence, Newnes-Butterworths, London, 168 p.
5. Brauner, G., 1973, Subsidence due to underground mining (in 2 parts)
1. Theory and Practices in predicting surface deformation:
U.S. Bur. of Mines Inf. Circ. 8751, 56 p.
6. _____, 1973, Subsidence due to underground mining (in 2 parts) 2.
Ground movements and mining damage: U.S. Bur. of Mines Inf. Circ.
8572, 53 p.
7. Candeub, Fleissig and Associates, 1971, Demonstration of a techniques for limiting the subsidence of land over abandoned mines, final report: City of Rock Springs, Wyo., 28 p.
8. _____, 1973, Demonstration of a technique for limiting the subsidence of land over abandoned mines, final report: City of Rock Springs, Wyo. 28 p.
9. Chugh, Yoginder P. and Karmis, Michael, 1982, State-of-the-art ground control in longwall mining and mining subsidence, Society of Mining Engineers of the American Institute of Mining, Metallurgical, and Petroleum Engineers, Inc., New York, New York, 327 p.

10. Colton, R.B., and Lowrie, R.L., 1973, Map showing mined areas of the Boulder-Weld coalfield, Colo.: U.S. Geol. Survey Misc. Field Studies Map, MF-513.
11. Davis, T., and Weimer, R.J., 1976, Late Cretaceous growth faulting, Denver Basin, Colo.: Prof. Contributions of Colorado School of Mines, 21 p.
12. Flaschentrager, H., 1958, Considerations on ground movement phenomena: Colliery Eng., v. 35, no. 8, p. 342-350 and no. 391-398.
13. General Accounting Office, 1979, Alternatives to protect property owners from damages caused by mine subsidence, National Technical Information Service, PB 290 869, 41 p. Office, PB 290 869.
14. General Analytics Inc., 1985, State of the Art of subsidence control, National Technical Information Service, PB 242 465, 265 p.
15. Geddes, J.D., 1978, Large Ground Movements and Structures, Proceedings of the Conference held at the University of Wales Institute of Science and Technology, Cardiff, July 1977, John Wiley and Sons, New York, 1064 p.
16. Grosvenor, N.E., 1964, Coal Mines of Colorado, Weld County (2 maps): Colorado School of Mines Found., Golden, Co.
17. Holt, R.D., 1972, Bibliography, Coal Resources of Colorado: Colo. Geol. Survey Spec. Pub. No. 3, 15 p.
18. Hornbaker, A.L., and Holt, R.D., 1973 Coal Resources in Colorado, Geol. Survey Bull. 34-1, 32 p.
19. Kapp, W.A., and Williams, R.C., 1972, "Extraction of Coal in the Sydney Basin from Beneath Large Bodies of Water, 1972 Conference of the Australasian Inst. of Mining and Metallurgy, pp. 77-87.

20. King, H.J., and Whetton, J.T., 1958, Mechanics of mining subsidence: Colliery Eng., v. 35, no. 6, p. 247-252 and no. 7, p. 285-388.
21. Landis, E.R., 1959, Coal Resources of Colorado, U.S. Geol. Survey Bull. 1072-C, p. 131-232.
22. Lowrie, R.L., 1966, Analysis of the coal industry in Boulder-Weld coalfield Colorado: U.S. Bur. Mines Rept. Inv. 6726, 79 p.
23. Mohr, H.F., 1956, Influence of mining on strata: Mine and Quarry Eng., v. 22, no. 4, p. 140-152.
24. National Coal Board (Great Britain), 1966, Subsidence Engineer's Handbook: Nat. Coal Board Production Dept., London, 118 p.
25. Orchard, R.J., 1972, "Vitrified Clay Pipes in Areas of Mining Subsidence", Clay Pipe Development Association Limited, 17 p.
26. Panek, L.A., 1973, Program for control of surface subsidence: U.S. Bur. Mines Prog. Rept. No. 10011, 23 p.
27. Stefanko, R., 1973, Subsidence and ground movement, in SME Handbook: Soc. Mining Eng., Am. Inst. Mining, Met. Petr. Eng., Inc. NY, p. 13-2, 13-9.
28. Turchaninov, I.A., Iofis, M.A. and Kasparyan, E.V., 1979, Principles of Rock Mechanics: English Translation by A.L. Peabody, Terraspace Inc., Rockville, Md., 493 p.
29. Weimer, R.J., 1973, A guide to uppermost Cretaceous stratigraphy, central Front Range, Colo.: Mountain Geologist, v. 10, no. 3, p. 53-97.
30. Woodhuff, S.D., 1966, Methods of working coal and metal mines, vol. 2, Ground support methods: New York, Pergamon Press, 429 p.

31. Yokel, F.Y., Salmomone, L.A., Chung, R.M., 1981, Construction of housing in mine subsidence areas, National Technical Information Service, PB 81 174690, 24 p.
32. Zwartendyk, J., 1971, Economic aspects of surface subsidence resulting from underground mineral exploitation (Ph.D. Thesis): University Park, Pennsylvania State University, Microfilms, Ann Arbor, 411 p.

TRI-TOWNS SUBSIDENCE INVESTIGATION

Weld County, Colorado

MINING FEATURES

BY JEFFREY L. HYNES

EXPLANATION

DRILL HOLES

- Coal in place or other solid strata
- Minor void space encountered
- Significant void space encountered
- x Planned hole, not drilled

- Anticipated mine feature
- A ○ 3 Hole identification number
- Line designator

ANTICIPATED MINE FEATURES (Predicted from data on mine map)

- P Pillar
- R Room
- L Limit (beyond mined area)
- H Haulageway
- Feature not confirmed in hole
(Actual logs should be consulted to determine actual feature encountered)

MINE SHAFTS

- Mine main shaft
- △ Mine air shaft
- Boundary of undermined area and adjacent affected area with hachures toward mine
- D U Fault, trace, U-upthrown side, D-downthrown side
- 100— Depth to mined zone
- * (Evidence of an unmapped shaft in conjunction with drilling behavior and lost circulation in Hole K-2 indicate the likelihood of unreported, shallower mining at approximately 160 ft in this area.)

ACKNOWLEDGMENT

This study was funded by U.S. Government Grant No. G5127081, Division of Mined Land Reclamation, Inactive Mine Program, Colorado Department of Natural Resources.



400 200 0 400 800 FT

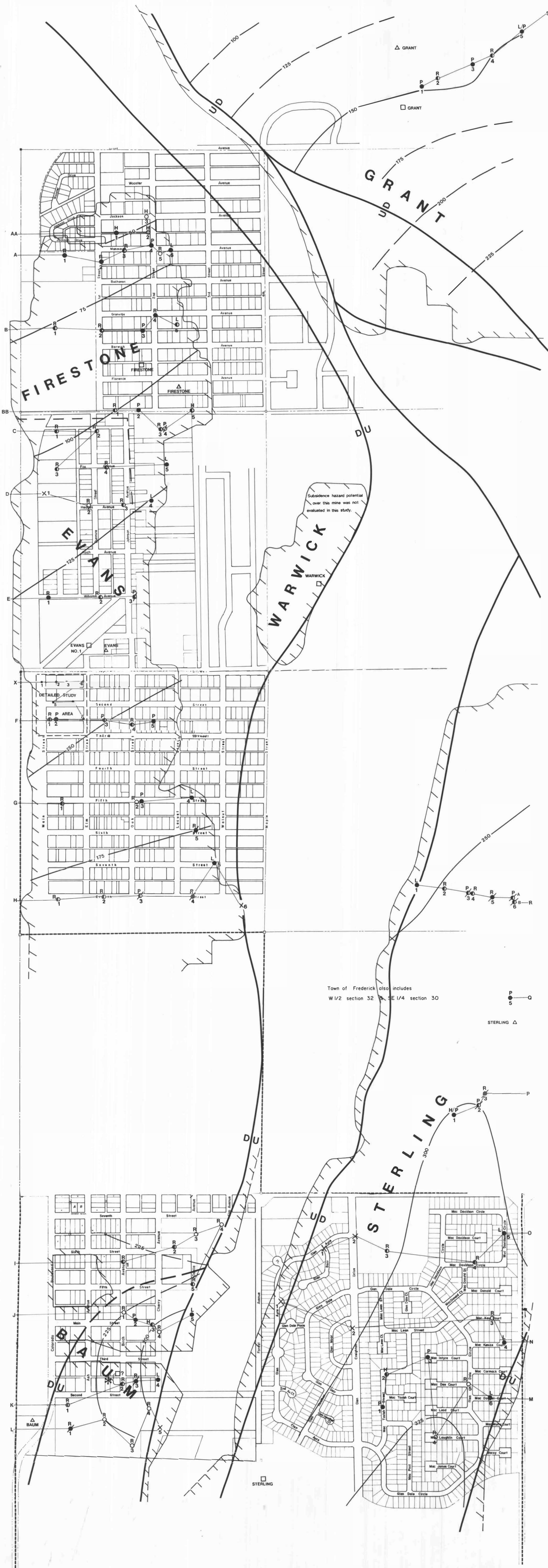

Town of Frederick also includes
W 1/2 section 32, E 1/4 section 30

STERLING △

STERLING

TRI-TOWNS SUBSIDENCE INVESTIGATION Weld County, Colorado

SUBSIDENCE EVALUATION AND HAZARD CLASSIFICATION

BY JEFFREY L. HYNES

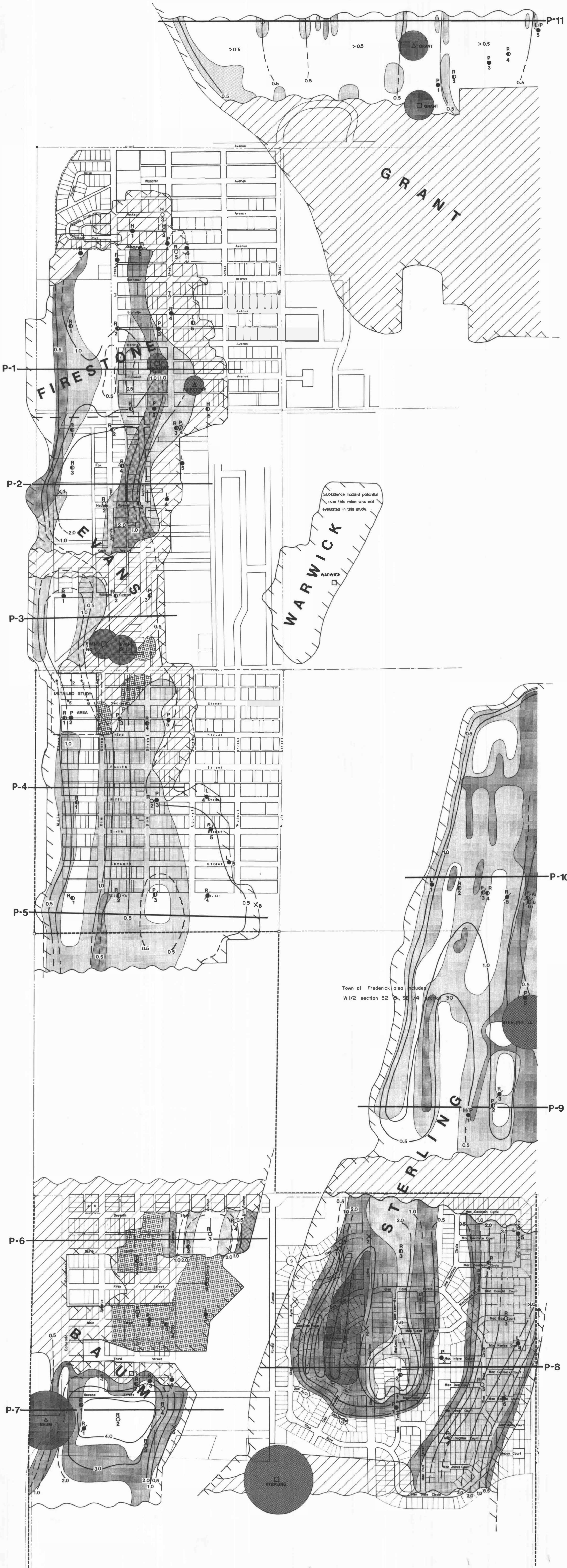

EXPLANATION

- DRILL HOLES**
- Coal in place or other solid strata
 - Minor void space encountered
 - Significant void space encountered
 - X Planned hole, not drilled
- ANTICIPATED MINE FEATURES**
(Predicted from data on mine map)
- P Pillar
 - R Room
 - L Limit (beyond mined area)
 - H Haulageway
 - Feature not confirmed in hole (Actual logs should be consulted to determine actual feature encountered)
- MINE SHAFTS**
- Mine main shaft
 - △ Mine air shaft
- CHARACTERIZATION OF MINE CONDITIONS**
(See accompanying text for further explanation)
- Category 1 -- not undermined
 - Category 2 -- undermined with pillars remaining in uniform distribution at approx. 50% extraction ratio. Not amenable to trough analysis and therefore, not evaluated further.
 - Category 3 -- undermined with pillars remaining in random distribution or with greater than 50% extraction ratio. Not amenable to trough analysis and therefore, not evaluated further.
 - Category 4 -- undermined with essentially total pillar extraction. Divided into Subsidence Hazard Zones on the basis of calculated horizontal strains derived from trough analysis.
- SUBSIDENCE HAZARD ZONES**
- Zone I -- horizontal ground strains less than or equal to .002
 - Zone II -- strains greater than .002 but less than .005
 - Zone III -- strains equal to or greater than .005 but less than .01
 - Zone IV -- strains equal to or greater than .01
- Shaft areas, radius of shaft Hazard Zone is equal to approx. depth of shaft (See accompanying text for further explanation)
- 1.0 — Subsidence contours -- calculated remaining vertical subsidence derived from trough analysis as above
- P-3 — Subsidence profile lines -- used to determine Subsidence Hazard Zones and vertical subsidence (See Appendix B in accompanying text for actual profiles and further explanation)

LIMITATIONS OF HAZARD CLASSIFICATION SYSTEM

Categories and Zones portrayed on this map are based upon an evaluation of available mine maps and the data collected during the drilling program.

They are intended to show the general degree of subsidence hazard associated with a particular area consistent with the degree of detail in this study. Further, site-specific studies incorporating greater detail may lead to the reclassification of any of the areas shown on this map.

Detailed, site-specific investigations are recommended to determine the subsidence hazard on all tracts of land in this study area which are in Category 2 and 3 or Zones II, III, & IV of Category 4. Subsidence effects anticipated in Category 1 and Zone I of Category 4 are very slight or negligible and should represent no risk to conventional construction. Therefore, no further subsidence evaluation should be required in area classified as Category 1 or Category 4, Zone I. (See accompanying text for further explanation.)

ACKNOWLEDGMENT

This study was funded by U.S. Government Grant No. G5127081, Division of Mined Land Reclamation, Inactive Mine Program, Colorado Department of Natural Resources.

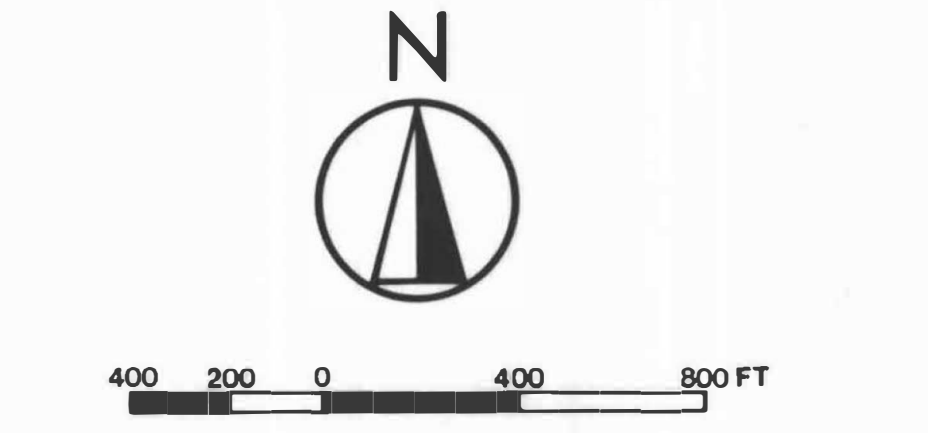

TRI-TOWNS SUBSIDENCE INVESTIGATION
Weld County, Colorado

REPRESENTATIVE CROSS-SECTIONS

BY JEFFREY L. HYNES
COLORADO GEOLOGICAL SURVEY

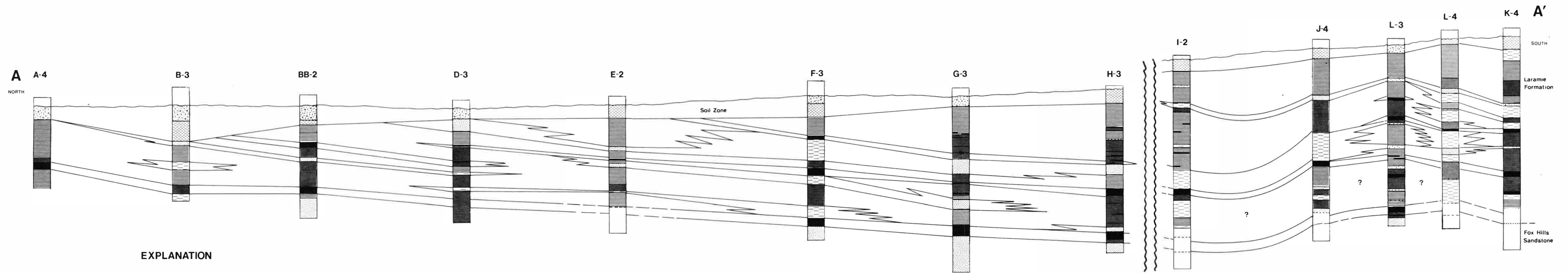
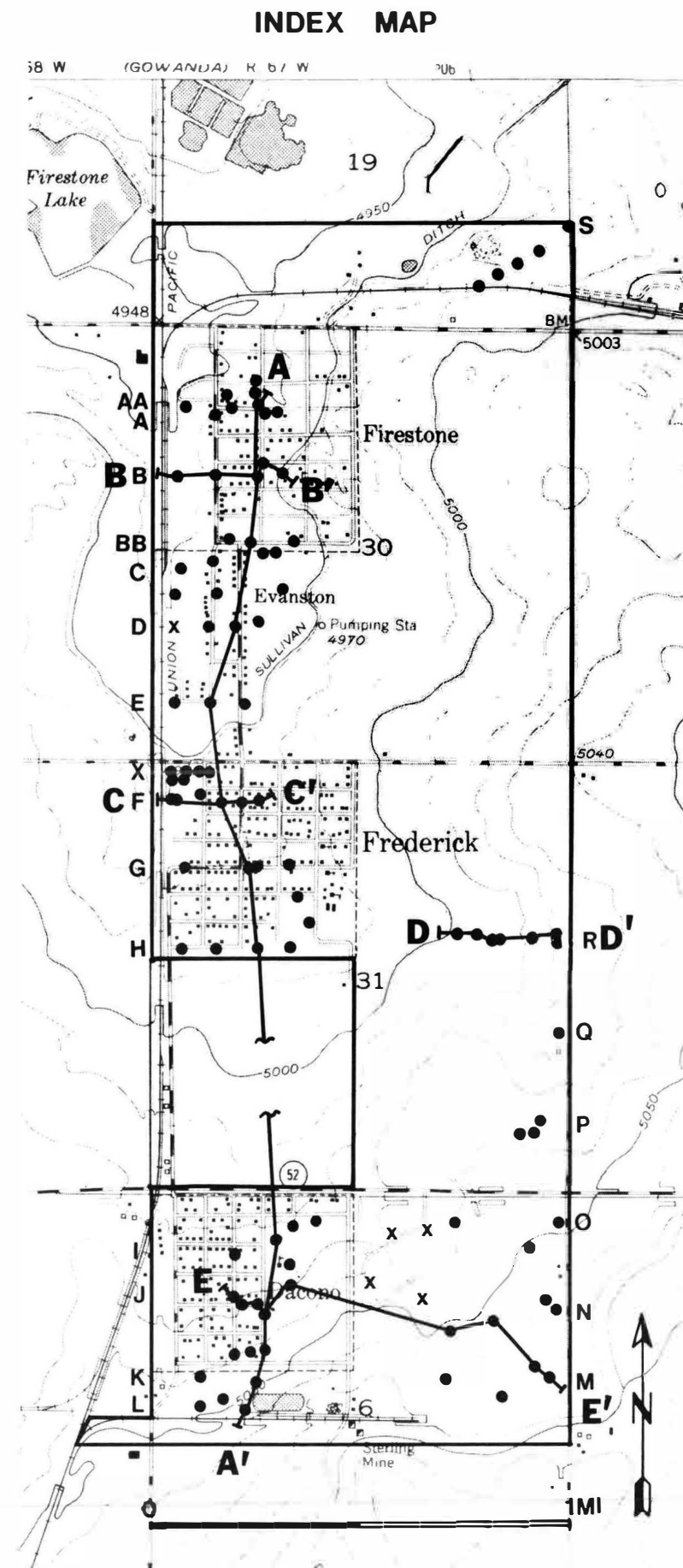

EXPLANATION

- | LITHOLOGY | SYMBOLS |
|---------------------------------|---|
| Sandy, coarse grained soils | BB-2 Drill hole designation |
| Clayey, fine grained soils | Correlation lines |
| Sandstone | Fault trace with arrow indicating upthrown side |
| Siltstone | Horizontal gap in section |
| Shale, claystone and mudstone | |
| Carbonaceous shale | |
| Coal | |
| Section drilled with no returns | |

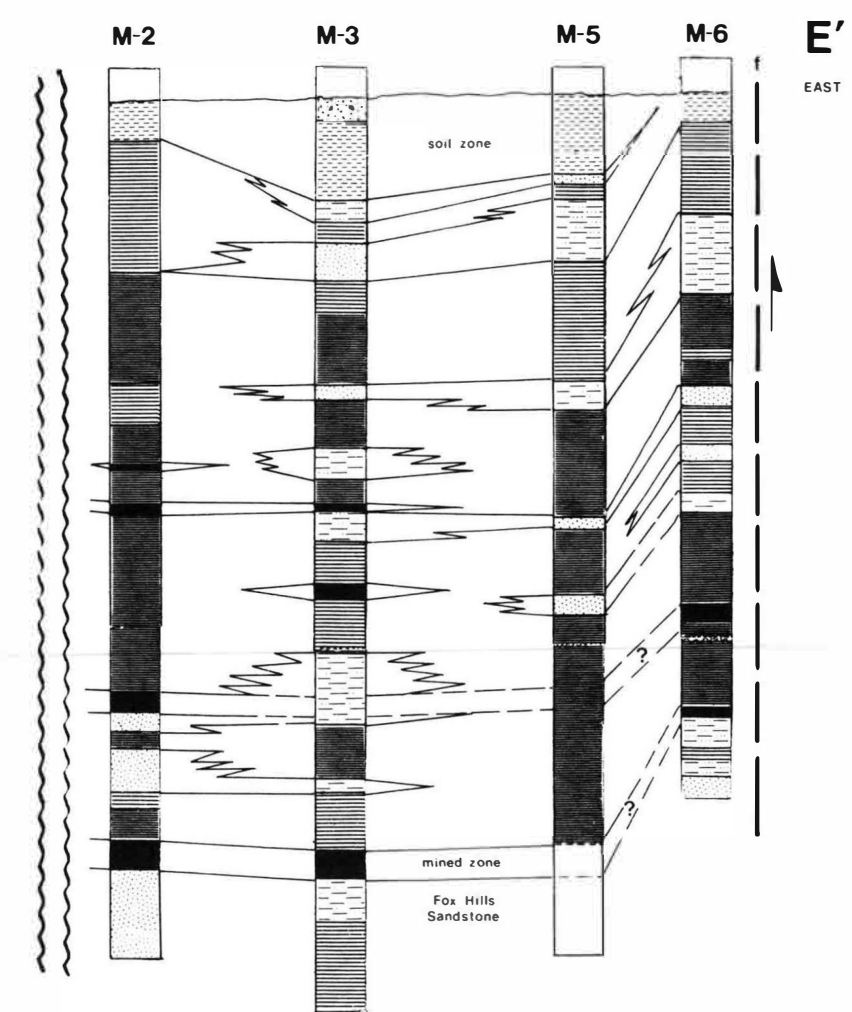
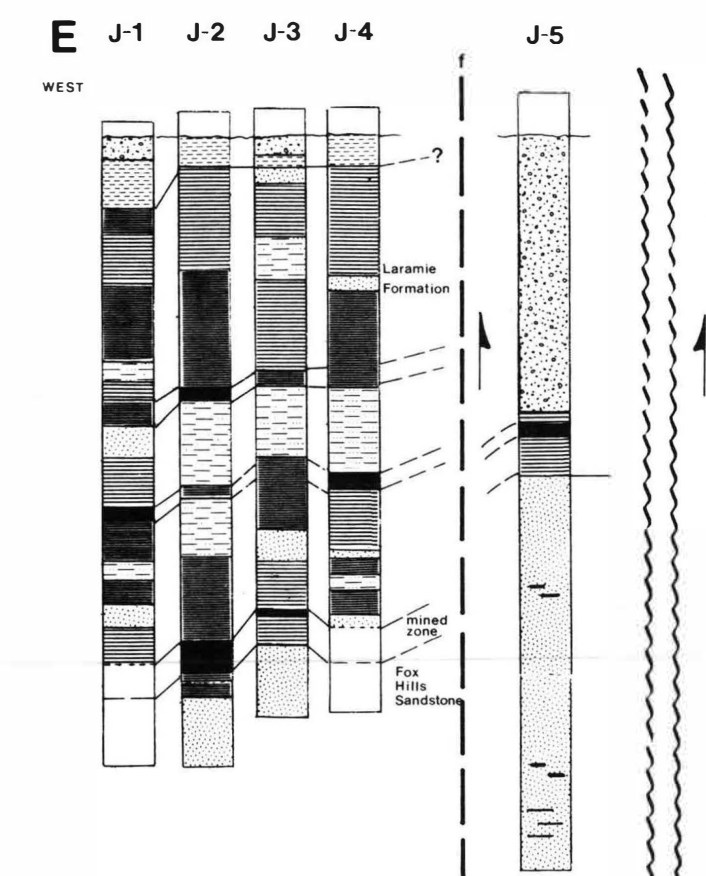
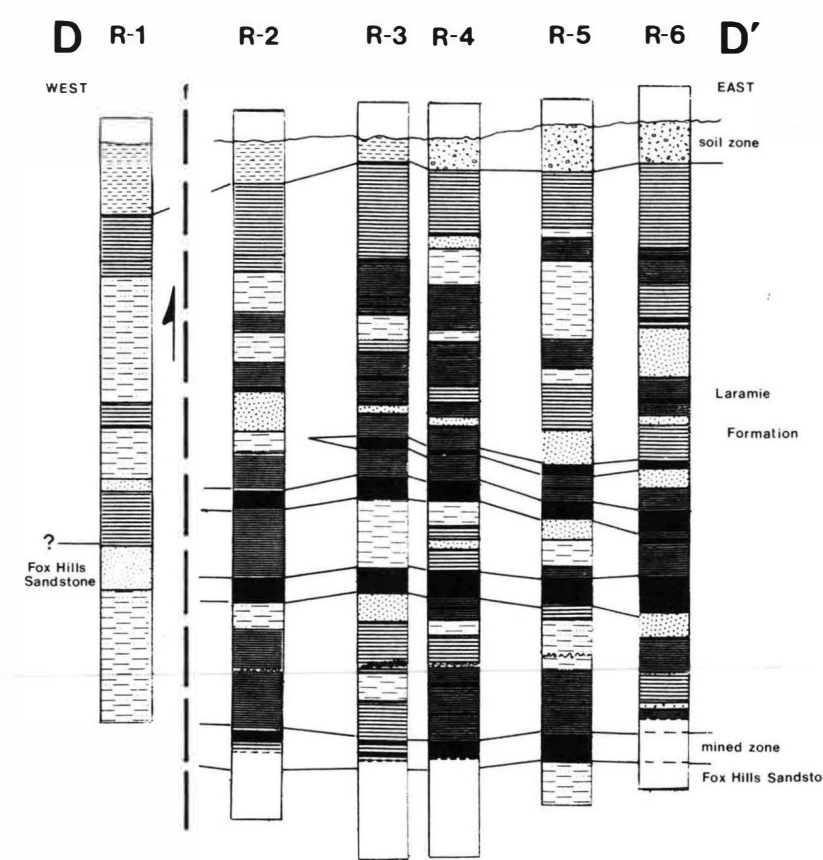
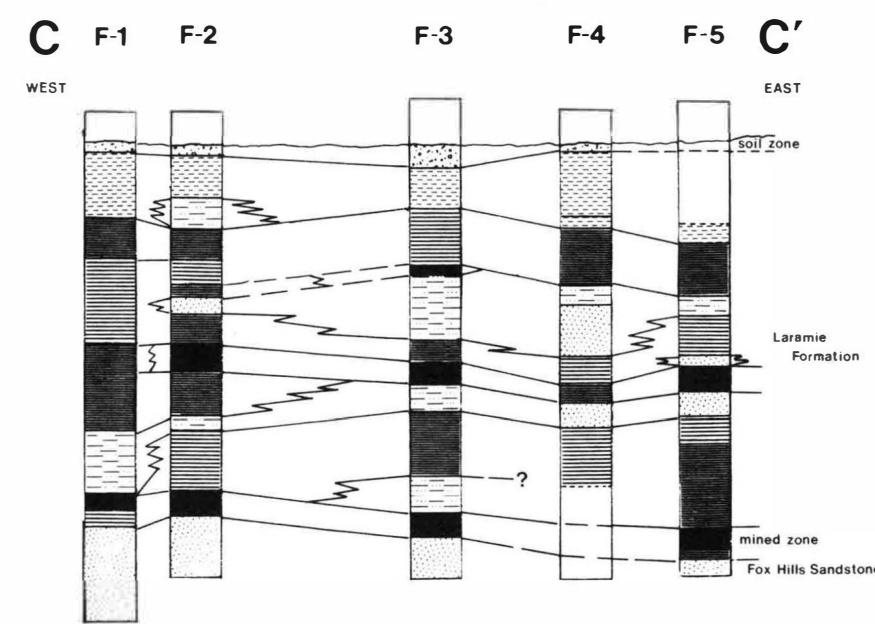
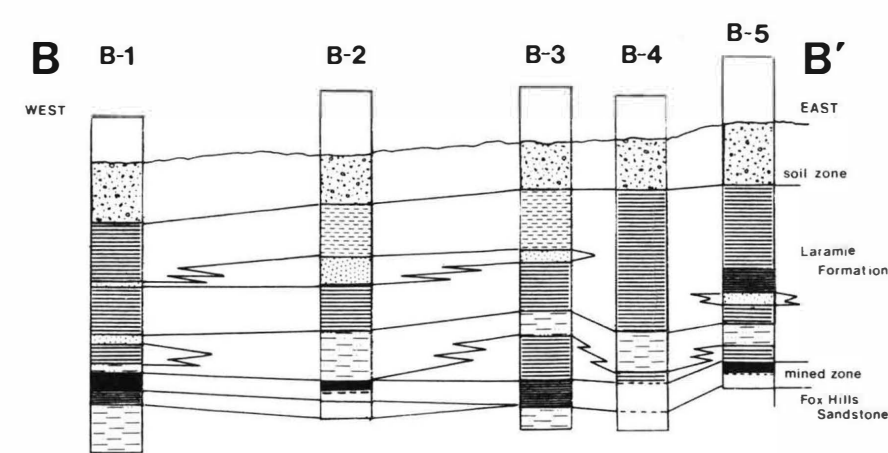

Appendix A

Representative Drill Logs

Original lithologic descriptions and geophysical logs for all drill holes are available for inspection, transcription and photo-copy reproduction in the offices of the Colorado Geological Survey, Denver.

COLORADO GEOLOGICAL SURVEY
 TRI-TOWN SUBSIDENCE INVESTIGATION
 DRILL HOLE LOG

Hole No. A-4

Date Logged: Aug 17, 1983

Drilled Depth: 100

Logged Depth: 100

Drilling Medium: water

Section: 30

Township: 2N

Range: 67W

Elevation(Ft): 4962

RADIATION LOG			ELECTRIC LOG		
Gamma	Density	Neutron	Scale	Scale	Scale
100	100		100		
Range (ft. in.)	10 50		Resistivity Scale (ft. in.)	10	
Counts Increasing to	→ →		S.P. Scale (mV in.)		
Depth Scale (ft. in.)	10 10		10 ⁴ Normal Resistivity (ft. in.)		
Logging Speed (ft. min.)	10 10		10 ⁴ Normal Resistivity (ft. in.)		
Time (min. sec.)	2 2		Logging Speed (ft. min.)	10	
Dead Time (microsec.)			Velocity (ft. min.)		
K-factor (x10 ³)			Arm. @ T/F		
Water Factor () in. hole			Arm. @ T/F		
Casing Factor () in. steel			Arm. @ T/F		
Probe Number	1530/1556		LOG		
Probe Dia. (in.)	1.875 1.875		Logged Depth (ft.)	100	
Crystal Size (in.)			Scale	BELOW 4.00	
Print Out (ft.)			Depth Scale (ft. in.)	10	
Reference Source (cps.)			Logging Speed (ft. min.)	10	

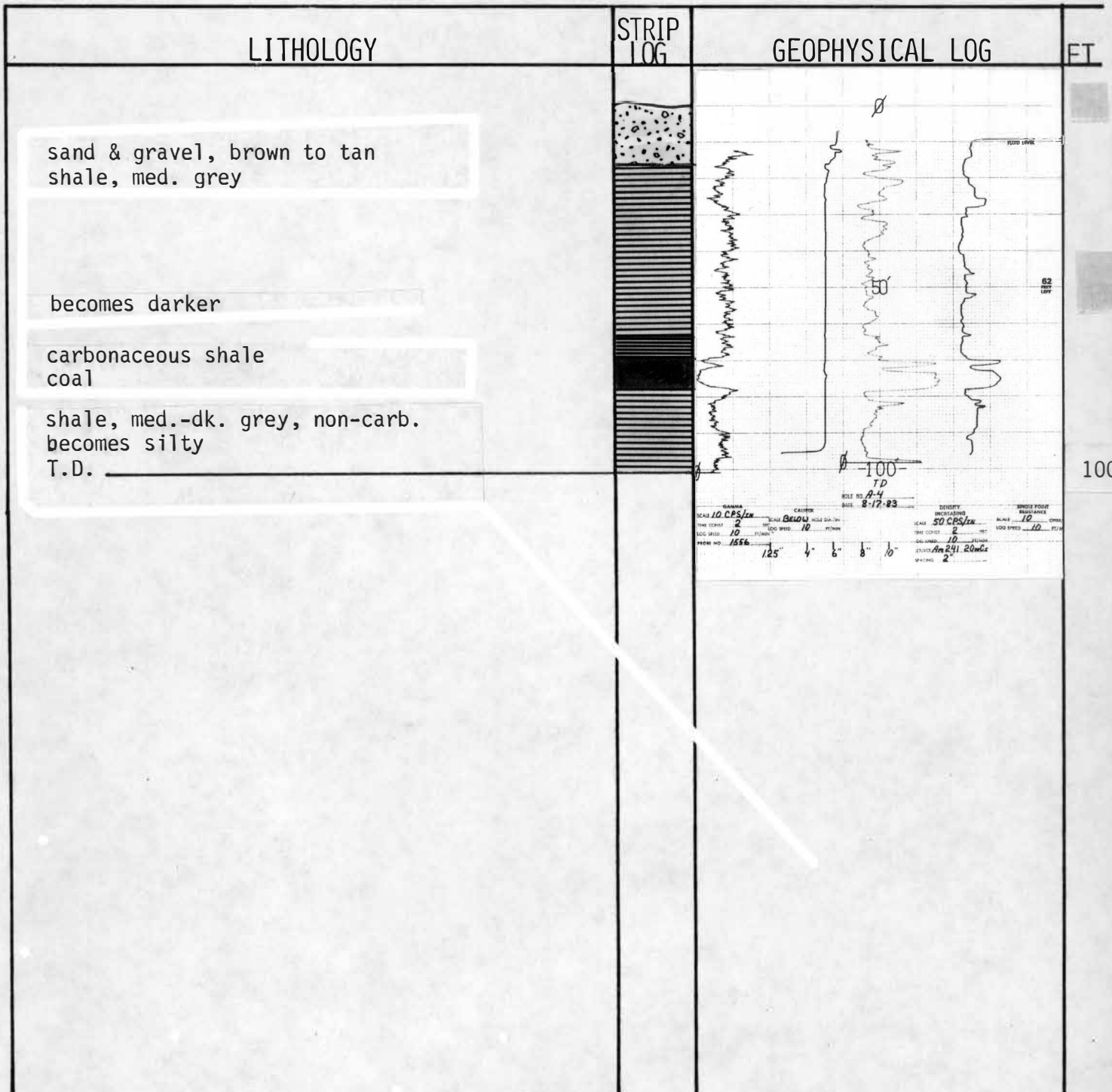

COLORADO GEOLOGICAL SURVEY
 TRI-TOWN SUBSIDENCE INVESTIGATION
 DRILL HOLE LOG

Hole No. BB-2

Date Logged: Sept 13, 1983

Section: 30

Drilled Depth: 141

Township: 2N

Logged Depth: 141

Range: 67W

Drilling Medium: water

Elevation(Ft): 4964

GAMMA LOG	Run 141	Run 137	Normal	ELECTRIC LOG	Run 135.5
Logged Depth (ft.)				Logged Depth (ft.)	
Run-in Interval (ft.)				Resistance Scale (ohm.)	10
Range (ft. in.)	10	30		S-P Scale (mv/in.)	
Counts Increasing to				16" Normal Resistivity (ohm.)	
Depth Scale (ft. in.)	10	10		80" Normal Resistivity (ohm.)	
Logging Speed (ft. min.)	10	10		Logging Speed (ft. min.)	10
Time Constant(s)	2	2		Viscosity-Density	
Dead Time (secs.)				Pan. @ 17"	
K-factor (x10 ⁷)				Ranf. @ 17"	
Water Factor (1 in. hole)				CALIPER LOG	
Casing Factor (1 in. steel)	1005	1050		Logged Depth (ft.)	135
Probe Number				Scale	BELOW LOG
Probe Dia. (in.)				Depth Scale (ft. in.)	10
Crystal Size (in.)				Logging Speed (ft. min.)	10
Print Out (ft.)					
Reference Source (cps.)					

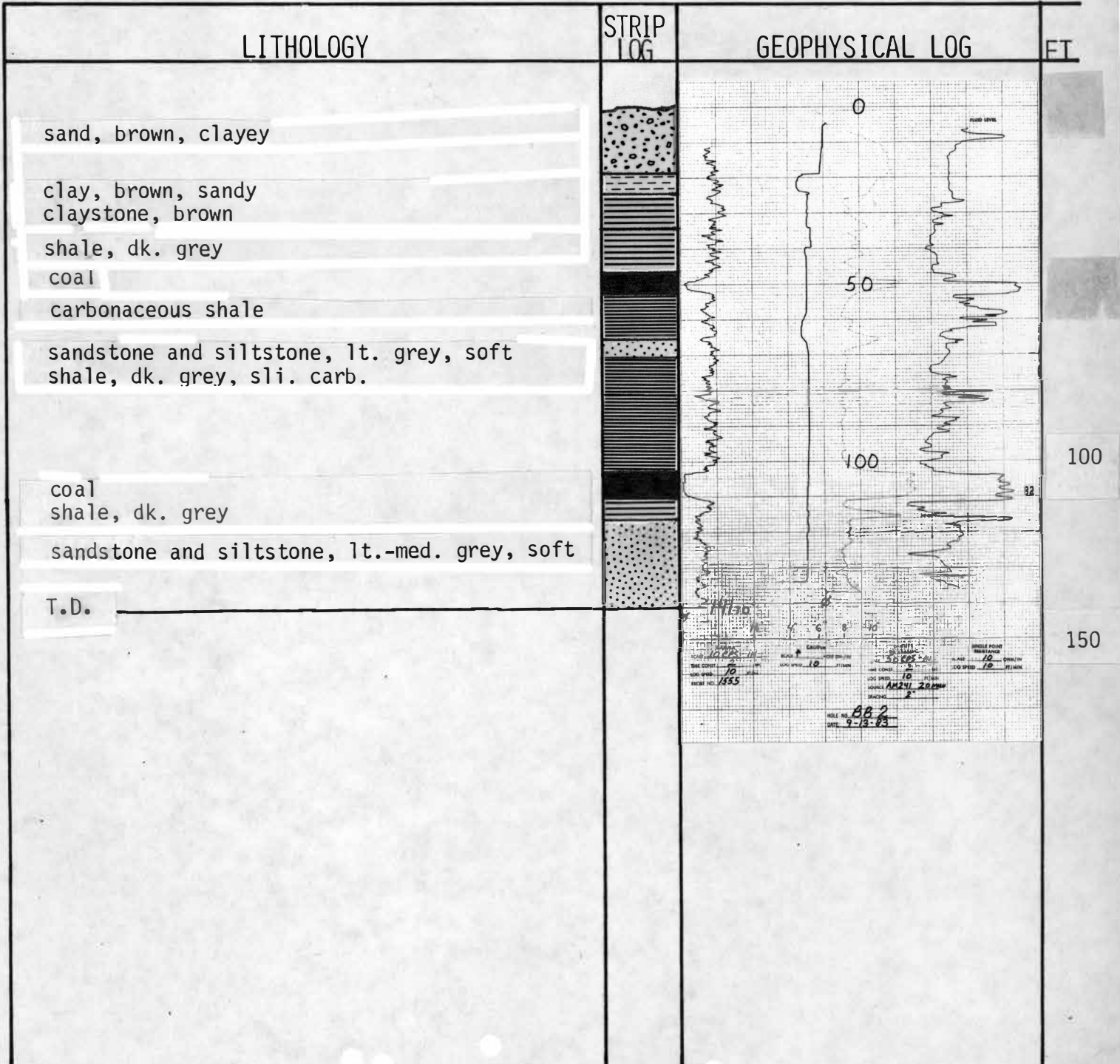

COLORADO GEOLOGICAL SURVEY
TRI-TOWN SUBSIDENCE INVESTIGATION
DRILL HOLE LOG

Hole No. D-3

Date Logged: Aug 22, 1983

Drilled Depth: 141

Logged Depth: 141

Drilling Medium: water

Section: 30

Township: 2N

Range: 67W

Elevation(Ft): 4960

RADIATION LOG			ELECTRIC LOG		
Logged Depth (ft.)	Gamma	Counts	Logged Depth (ft.)	Resistance Scale (ohm-ft)	Scale
Range (ft.)	1/1	1/1	1/1	1/1	1/1
Counts Increasing to			10	50	10
Depth Scale (ft./in.)	10	10	10	10	10
Logging Speed (ft./min.)	10	10	10	10	10
Time Constant(s)	2	2			
Dead Time (Lugs)					
K-factor (x10 ³)					
Water Factor (1 in hole)					
Casing Factor (1 in steel)					
Probe Number	1555/1550				
Probe Size (in.)					
Crystal Size (in.)					
Probe Log (ft.)					
Reference Source (cps)					

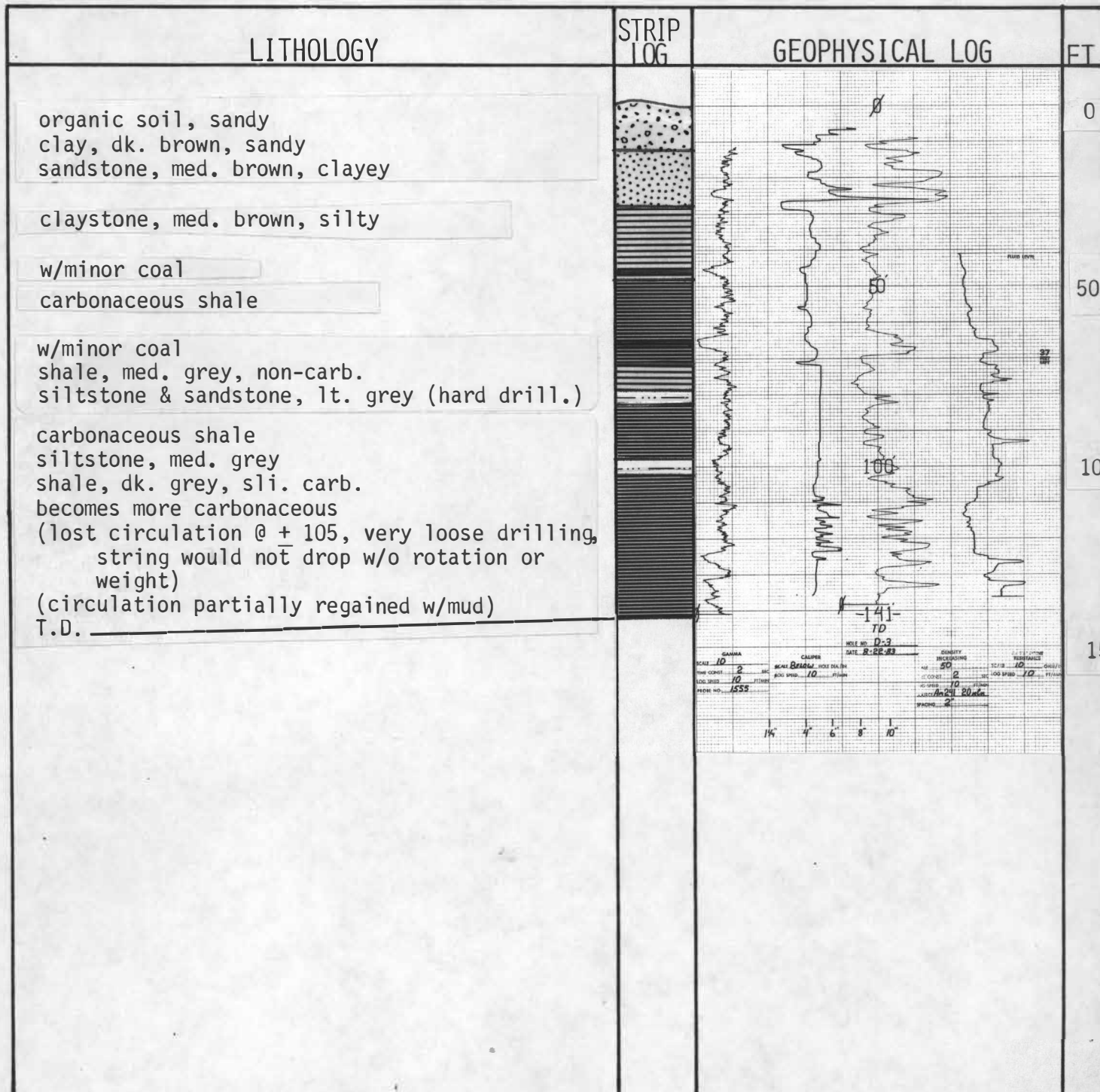

COLORADO GEOLOGICAL SURVEY
 TRI-TOWN SUBSIDENCE INVESTIGATION
 DRILL HOLE LOG

Hole No. E-2

Date Logged: Aug 22, 1983

Drilled Depth: 161

Logged Depth: 161

Drilling Medium: water

Section: 30

Township: 2N

Range: 67W

Elevation(Ft): 4966

RADIATION LOG			ELECTRIC LOG		
Gamma	Counts	Neutron	Logged Depth (ft.)	Resistance Scale (ohm)	SP Scale (mv)
161	161		161	10	
Range (cpm-ft.)			SP Normal Resistivity (ohm-ft)		
Counts Increasing 50	10	50	SP Normal Resistivity (ohm-ft)		
Depth Scale (ft.-in.)	10	10	Logging Speed (ft./min.)	10	
Logging Speed (ft./min.)	10	10	Viscosity - Chemistry		
Time Constant (sec)	10	10	Temp @ 10'		
Dead Time (µsec)	10	10	Temp @ 20'		
K-factor (x 10 ³)			Temp @ 30'		
Water Factor (1 in. hole)			Temp @ 40'		
Counting Factor (1 in. hole)			Temp @ 50'		
Probe Diameter	1.555	1.500	Temp @ 60'		
Crystal Size (in.)			Temp @ 70'		
Probe Out (ft.)			Temp @ 80'		
Reference Source (logs)			Temp @ 90'		

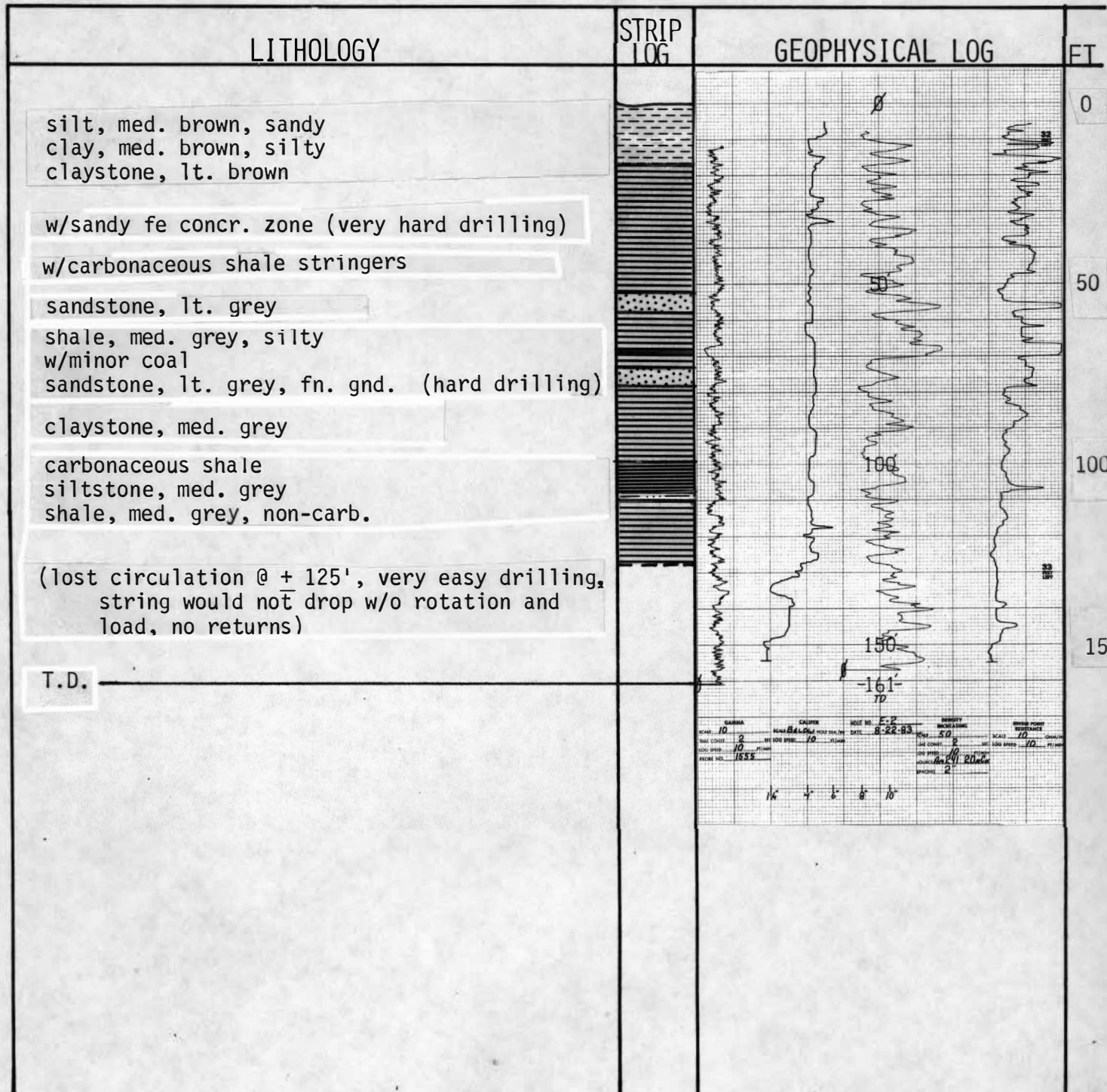

COLORADO GEOLOGICAL SURVEY
 TRI-TOWN SUBSIDENCE INVESTIGATION
 DRILL HOLE LOG

Hole No. G-3

Date Logged: Aug 25, 1983

Section: 31

Drilled Depth: 220

Township: 2N

Logged Depth: 220

Range: 67W

Drilling Medium: water

Elevation(Ft): 4978

RADIATION LOG			ELECTRIC LOG		
Depth (ft.)	Gamma	Neutron	Depth (ft.)	Resistivity	Sp. P.
Logged Depth (ft.)	220	220	Logged Depth (ft.)	220	
Range (ft. in.)	10	50	Resistivity Scale (ft. in.)	10	
Counts increasing to	10	10	S.P. Scale (mV/in.)		
Depth Scale (ft. in.)	10	10	1 FT Normal Resistivity (ft. in.)		
Logging Speed (ft. min.)	2	2	64" Normal Resistivity (ft. in.)		
Time Conversion:			Logging Speed (ft. min.)	10	
Dead Time (secs.)			Velocity (ft. min.)		
K-factor (ft. in.)			Area @ 1 FT		
Water Factor () in. hole			Area @ 1 FT		
Cement Factor () in. steel					
Probe Number	1555	1550			
Probe Dia. (in.)					
Cement Dia. (in.)					
Probe Dia. (ft.)					
Reference Source (logs)					

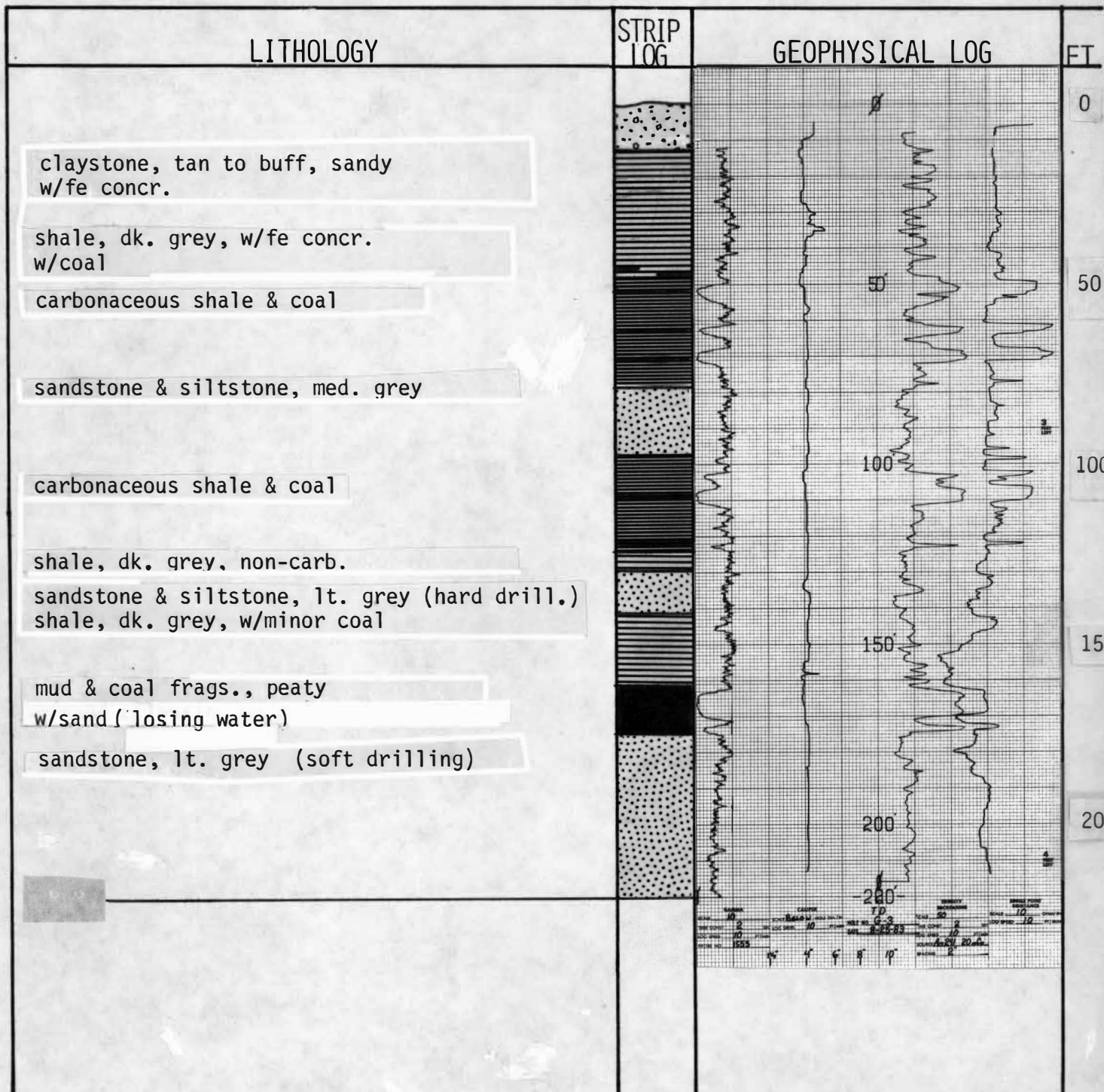

COLORADO GEOLOGICAL SURVEY
 TRI-TOWN SUBSIDENCE INVESTIGATION
 DRILL HOLE LOG

Hole No. H-3

Date Logged: Aug 26, 1983

Drilled Depth: 202

Logged Depth: 202

Drilling Medium: water

Section: 31

Township: 2N

Range: 67W

Elevation(Ft): 4987

RADIATION LOG			ELECTRIC LOG		
Gamma	Density	Neutron	Gamma	Density	Neutron
202	202		202		
Range (cps/in.)	10	20	Range (cps/in.)	10	
Counts Increasing (cp)	→	→	Scale (mV/in.)		
Depth Scale (ft./in.)	10	10	10" Normal Resistivity (Ωm/in.)		
Logging Speed (ft./min.)	2	12	64" Normal Resistivity (Ωm/in.)		
Total Gamma (cp)			Logging Speed (ft./min.)	10	
Count Time (min.)			Velocity (ft./min.)		
K-Factor (x10 ⁴)			Arm. @ 1" P		
Water Factor () in. hole			Arm. @ 1 1/2"		
Casing Factor () in. steel					
Probe Number	1555	1500			
Probe Dia. (in.)					
Crystal Size (in.)					
Probe Dia. (ft.)					
Reference Source (cps)					

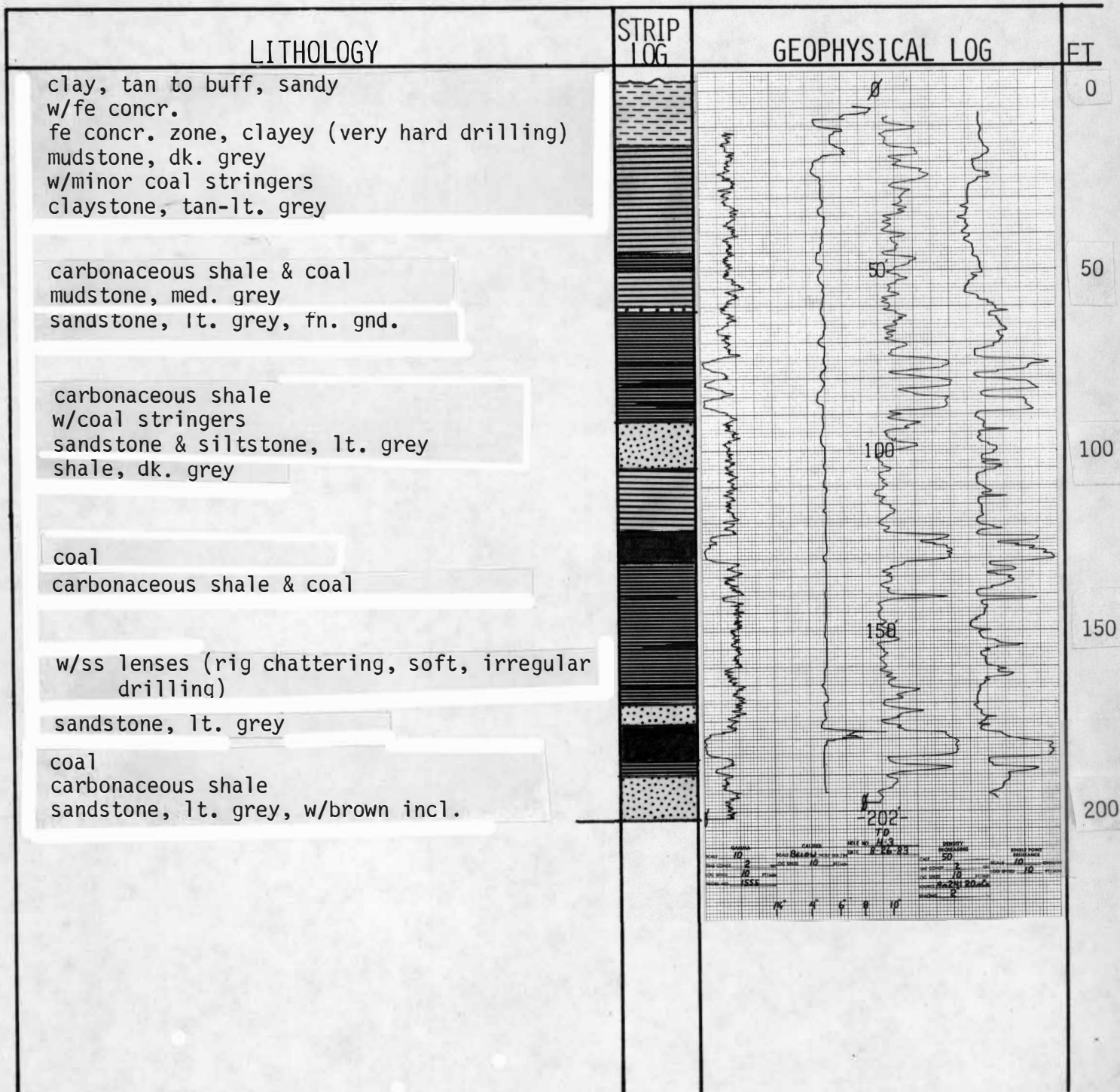

COLORADO GEOLOGICAL SURVEY
 TRI-TOWN SUBSIDENCE INVESTIGATION
 DRILL HOLE LOG

Hole No. K-4

Date Logged: Sept 2, 1983

Drilled Depth: 226

Logged Depth: 226

Drilling Medium: water

Section: 6

Township: 1N

Range: 67W

Elevation(Ft): 5042

RADIATION LOG				ELECTRIC LOG			
Logged Depth (ft.)	226	Density	222	Logged Depth (ft.)	226		
Shallow Interval (ft.)				Resistance Scale (ohm.)	70		
Range Log (ft. in.)	10	Scale	50	S.P. Scale (mv/in.)			
Counts (Normalizing log)				10° Normal Resistivity (ohm-in.)			
Depth Scale (ft. in.)	10	Scale	10	64° Normal Resistivity (ohm-in.)			
Logging Speed (ft. min.)	10		10	Logging Speed (ft. min.)	10		
Time (minutes)				Velocity Density			
Depth (Total Log)				Res. @ 1" / 1"			
Res. Factor (10°)				Res. @ 1" / 4"			
Water Factor (1 in. hole)				Res. @ 1" / 8"			
Logging Factor (1 in. stone)	155	155					
Probe Dia. (in.)				CALIPER LOG			
Crystal Size (in.)				Logged Depth (ft.)	226		
Probe Dia. (ft.)				Scale	BELOW LOG		
Reference Source Log				Depth (Scale (ft. in.))	10		
				Logging Speed (ft. min.)	10		

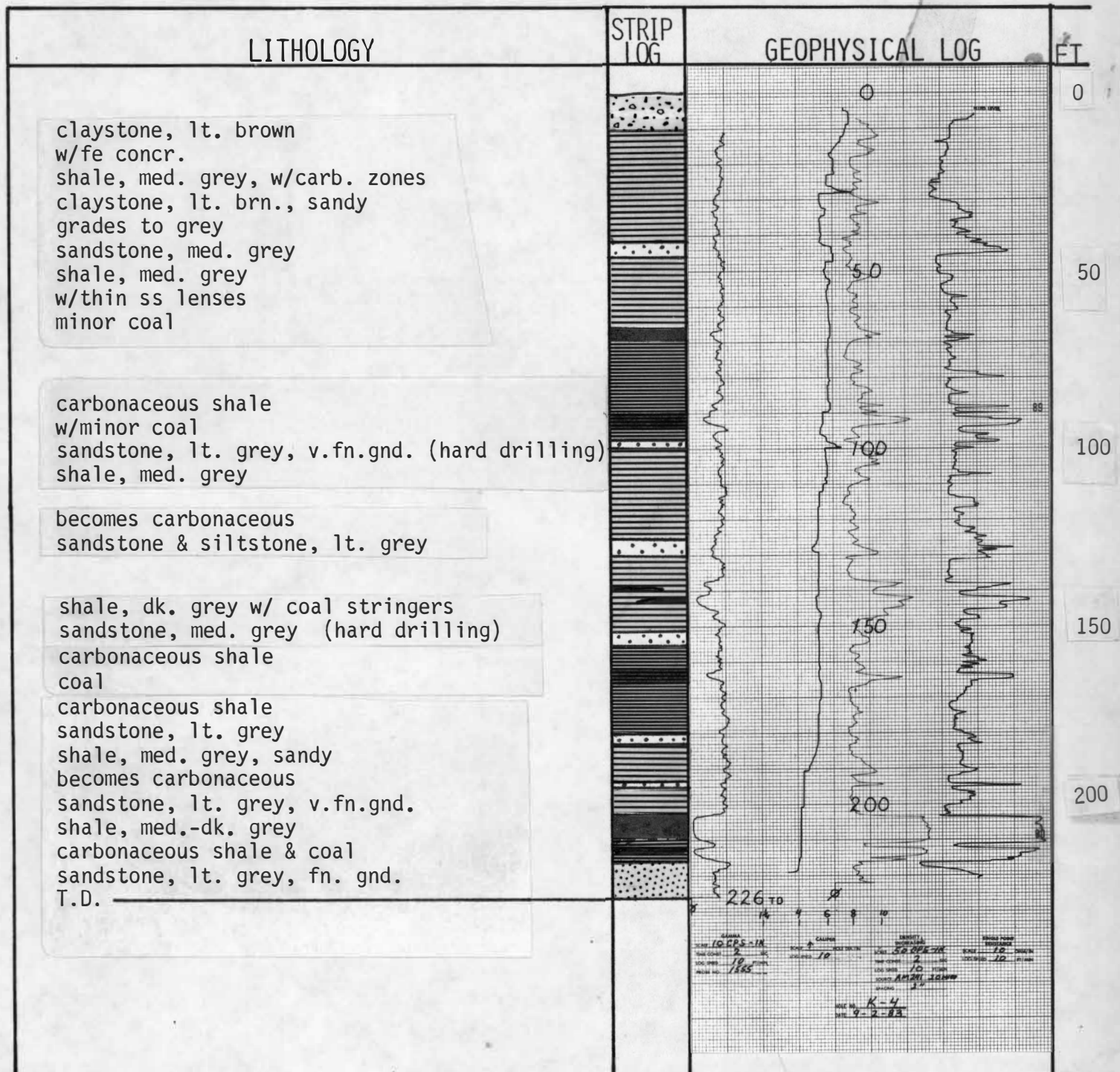

claystone, lt. brown w/fe concr.
 shale, med. grey, w/carb. zones
 claystone, lt. brn., sandy grades to grey
 sandstone, med. grey
 shale, med. grey w/thin ss lenses
 minor coal

carbonaceous shale w/minor coal
 sandstone, lt. grey, v.fn.gnd. (hard drilling)
 shale, med. grey

becomes carbonaceous sandstone & siltstone, lt. grey

shale, dk. grey w/ coal stringers
 sandstone, med. grey (hard drilling)
 carbonaceous shale
 coal

carbonaceous shale
 sandstone, lt. grey
 shale, med. grey, sandy
 becomes carbonaceous
 sandstone, lt. grey, v.fn.gnd.
 shale, med.-dk. grey
 carbonaceous shale & coal
 sandstone, lt. grey, fn. gnd.
 T.D.

226 TO

LOG NO. 10-83-18
 DATE LOGGED 9-2-83
 LOGGERS 185

CALIPER
 SCALE 10
 LOGGERS 185

SURFACE
 LOG NO. 10-83-18
 DATE LOGGED 9-2-83
 LOGGERS 185

WELL NO. K-4
 DATE 9-2-83

COLORADO GEOLOGICAL SURVEY
 TRI-TOWN SUBSIDENCE INVESTIGATION
 DRILL HOLE LOG

Hole No. I-2

Date Logged: Aug 29, 1983

Drilled Depth: 262

Logged Depth: 262

Drilling Medium: water

Section: 6

Township: 1N

Range: 67W

Elevation(Ft): 5023

RADIATION LOG			ELECTRIC LOG		
Logged Depth (ft.)	262	262	Logged Depth (ft.)	262	
Planon Interval (ft.)			Resistance Scale (ohm.)	10	
Planon Scale (in.)	10	50	S.P. Scale (mV/in.)		
Counts Increasing to	→	→	SP Normal Resistivity (ohm.)		
Depth Scale (ft./in.)	10	10	SP Normal Resistivity (ohm.)		
Logging Speed (ft./min.)	10	10	Logging Speed (ft./min.)	10	
Time Consideration	R	R	Viscosity Density		
Count Error (approx.)			Res. @ 7 1/2'		
K-factor (x10 ⁷)			Res. @ 15'		
Water Factor (1 in. hole)			LOG		
Casing Factor (1 in. steel)			Logged Depth (ft.)	262	
Probe Number	1555	1555	Scale	10	10
Probe Dia. (in.)			Depth Scale (ft./in.)	10	
Crystal Size (in.)			Logging Speed (ft./min.)	10	
Print Out (ft.)					
Reference Source (ppm.)					

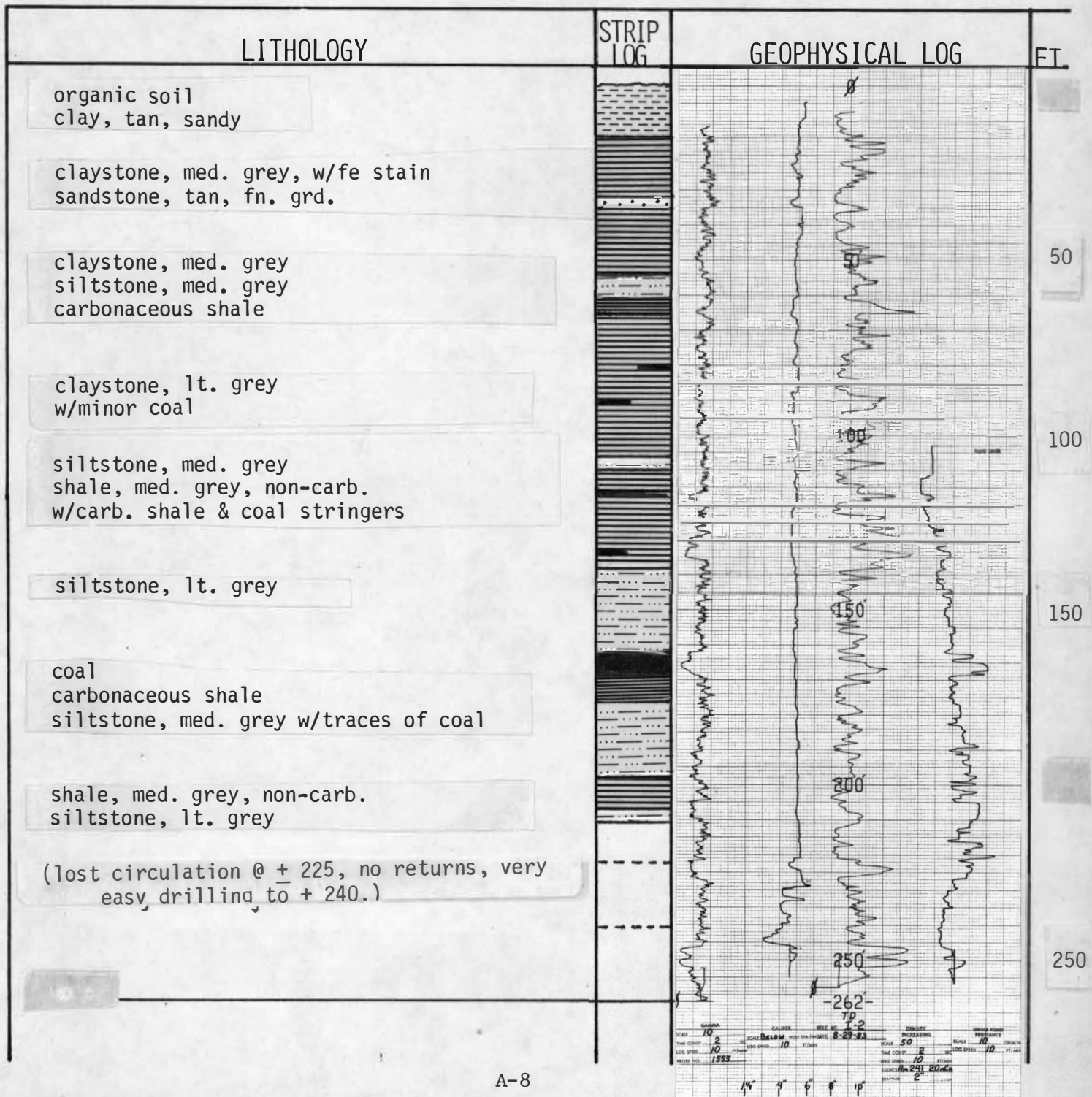

COLORADO GEOLOGICAL SURVEY
 TRI-TOWN SUBSIDENCE INVESTIGATION
 DRILL HOLE LOG

Hole No. L-4

Date Logged: Sept 1, 1983

Drilled Depth: 240

Logged Depth: 238

Drilling Medium: water

Section: 6

Township: 1N

Range: 67W

Elevation(Ft): 5048

RADIATION LOG				ELECTRIC LOG			
Logged Depth (ft.)	238	234		Logged Depth (ft.)	232.5		
Penetration Rate (ft./min.)	10	50		Resistance Scale (ohm-in.)	10		
Range (ft. in.)	10	10		S.P. Scale (mv/in.)			
Counts Increasing to	10	10		10" Normal Resistivity (ohm-in.)			
Depth Scale (ft. in.)	10	10		64" Normal Resistivity (ohm-in.)	10		
Logging Speed (ft./min.)	2	2		Logging Speed (ft./min.)			
Time Corrections				Specific Gravity			
Dead Time (secs.)				Pen. @ 1"			
K Factor (x10 ³)				Pen. @ 1'			
Water Factor (1 in. hole)				Pen. @ 1'			
Casing Factor (1 in. steel)							
Probe Number	1555/1550			CALIPER LOG			
Probe Dia. (in.)				Logged Depth (ft.)	232		
Crystal Size (in.)				Scale	Below Log		
Probe Cal. (ft.)				Depth Scale (ft. in.)			
Reference Source (logs)				Logging Speed (ft./min.)			

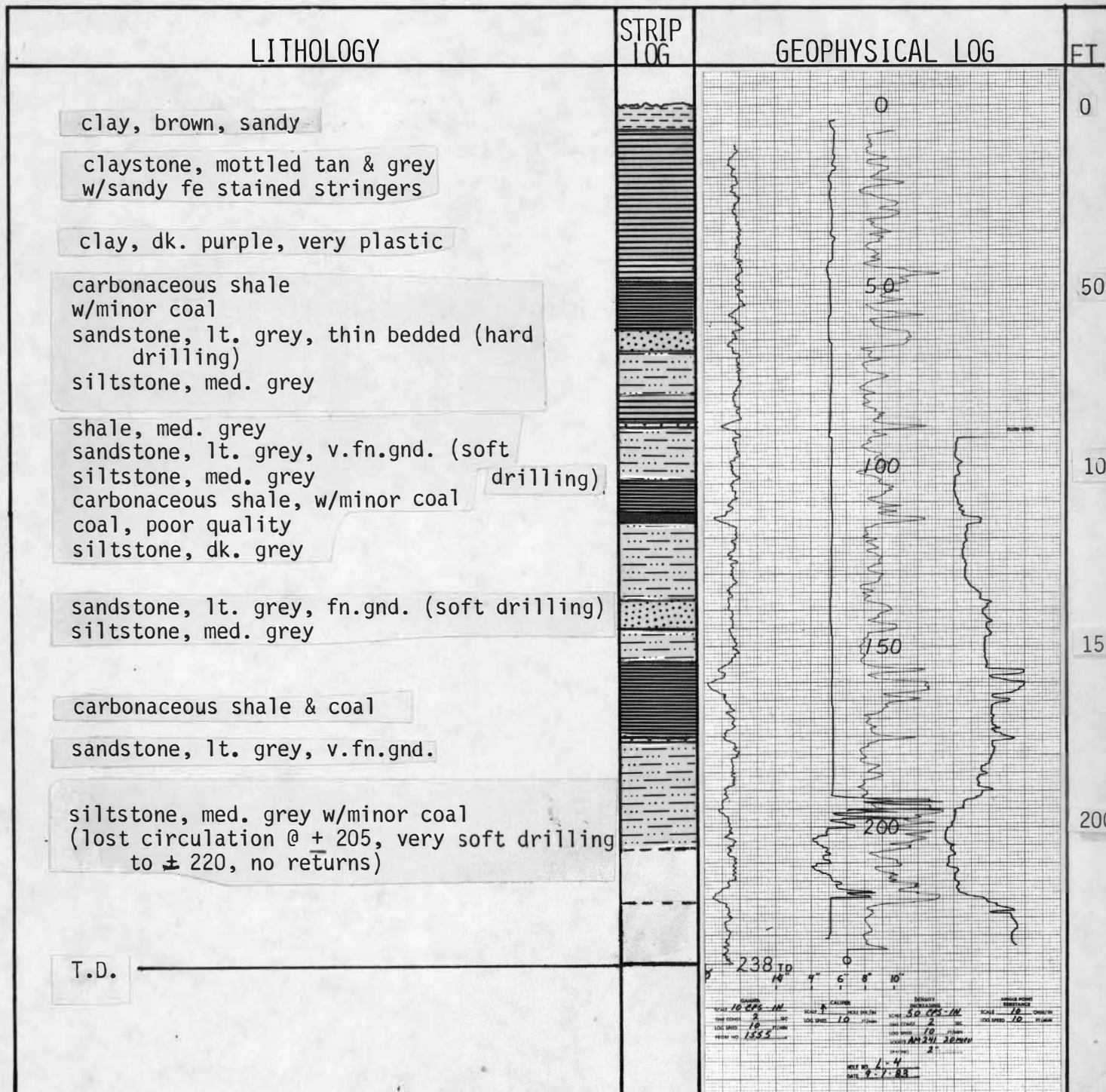

COLORADO GEOLOGICAL SURVEY
 TRI-TOWN SUBSIDENCE INVESTIGATION
 DRILL HOLE LOG

Hole No. L-3

Date Logged: Sept 1, 1983

Drilled Depth: 262

Logged Depth: 262

Drilling Medium: water

Section: 6

Township: 1N

Range: 67W

Elevation(Ft): 5052

RADIATION LOG			ELECTRIC LOG		
Logged Depth (ft.)	262	258	Logged Depth (ft.)	256	5
Range (cps/in.)	10	50	Resistance Scale (ohm-in.)	10	
Source Increasing to	10	10	S.P. Scale (mv/in.)		
Depth Scale (ft./in.)	10	10	100 Normal Resistivity (ohm-in.)		
Logging Speed (ft./min.)	10	10	Logging Speed (ft./min.)	10	
Time (Conductance)	2	2	Viscosity-Density		
Dead Time (microsec.)			Rm. @ 1°F		
Factor (ohm-in.)			Rm. @ 75°F		
Water Factor (1 in. hole)			Caliper Log		
Casing Factor (1 in. steel)	1555	1550	Logged Depth (ft.)	256	
Probe Number			Scale	Below 10.6	
Probe Dia. (in.)			Depth Scale (ft./in.)	10	
Crystal Size (in.)			Logging Speed (ft./min.)	10	
Probe Out (ft.)					
Reference Source (cps)					

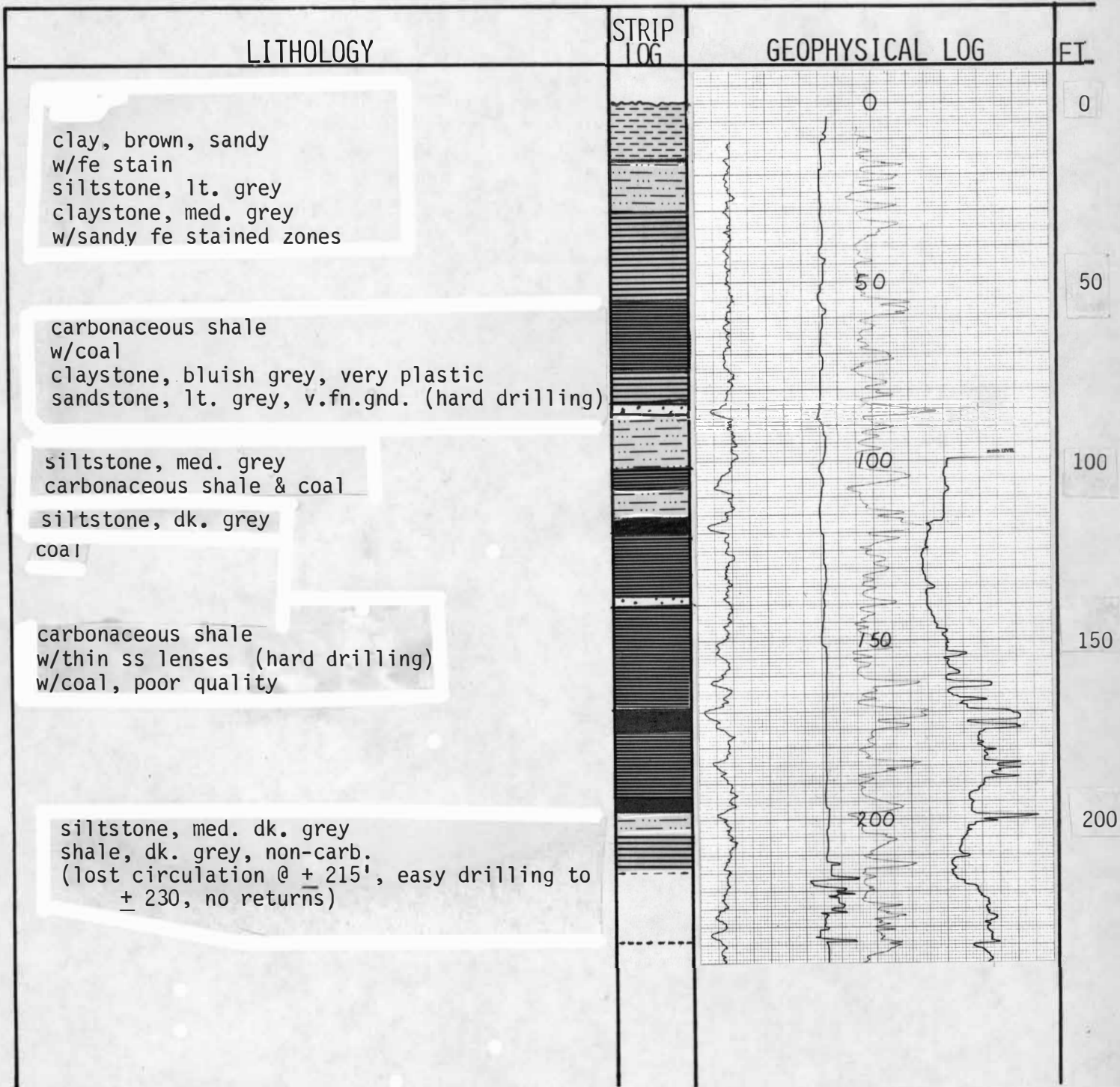

LITHOLOGY	STRIP LOG	GEOPHYSICAL LOG	FT																				
<div style="position: absolute; top: 10%; left: 10%; border: 1px solid black; padding: 2px;">T.D.</div>		<div style="position: absolute; top: 10%; right: 10%; border: 1px solid black; padding: 2px;">250</div> <div style="position: absolute; top: 15%; left: 15%; font-size: small;"> <table border="1"> <tr> <td>BARBAR</td> <td>CALLER</td> <td>SHEET</td> <td>WELL POINT</td> </tr> <tr> <td>NO. 1000-121</td> <td>NO. 1</td> <td>NO. 50</td> <td>NO. 10</td> </tr> <tr> <td>LOG NO. 2</td> <td>LOG DATE 10</td> <td>LOG TIME 10</td> <td>LOG SPEED 10</td> </tr> <tr> <td>LOG SPEED 10</td> <td>LOG TIME 10</td> <td>LOG SPEED 10</td> <td>LOG TIME 10</td> </tr> <tr> <td>LOG DATE 1935</td> <td>LOG TIME 10</td> <td>LOG SPEED 10</td> <td>LOG TIME 10</td> </tr> </table> </div> <div style="position: absolute; top: 25%; left: 70%; font-size: x-small;"> <p>WELL L-3 DATE 9-1-33</p> </div>	BARBAR	CALLER	SHEET	WELL POINT	NO. 1000-121	NO. 1	NO. 50	NO. 10	LOG NO. 2	LOG DATE 10	LOG TIME 10	LOG SPEED 10	LOG SPEED 10	LOG TIME 10	LOG SPEED 10	LOG TIME 10	LOG DATE 1935	LOG TIME 10	LOG SPEED 10	LOG TIME 10	
BARBAR	CALLER	SHEET	WELL POINT																				
NO. 1000-121	NO. 1	NO. 50	NO. 10																				
LOG NO. 2	LOG DATE 10	LOG TIME 10	LOG SPEED 10																				
LOG SPEED 10	LOG TIME 10	LOG SPEED 10	LOG TIME 10																				
LOG DATE 1935	LOG TIME 10	LOG SPEED 10	LOG TIME 10																				

COLORADO GEOLOGICAL SURVEY
 TRI-TOWN SUBSIDENCE INVESTIGATION
 DRILL HOLE LOG

Hole No. B-1

Date Logged: Aug 18, 1983

Drilled Depth: 121

Logged Depth: 121

Drilling Medium: water

Section: 30

Township: 2N

Range: 67W

Elevation(Ft): 4955

RADIATION LOG			ELECTRIC LOG		
Source	Depth	Reading	Source	Depth	Reading
Logged Depth (ft.)	121	121	Logged Depth (ft.)	121	121
Run-in Interval (ft.)			Resistance Scale (ohm.)		10
Range (cpm/in.)	10	50	10" Normal Resistivity (ohm/in.)		
Counts Increasing to	→	→	64" Normal Resistivity (ohm/in.)		
Depth Scale (ft. in.)	10	10	Logging Speed (ft./min.)		10
Logging Speed (ft./min.)	10	10	Viscosity-Density		
Time Constant(s)	2	2	Pen. @ 1" (in.)		
Dead Time (sec.)			Pen. @ 1" (in.)		
K-factor (x10 ³)			Pen. @ 1" (in.)		
Water Factor (1 in. hole)			LOG		
Logging Factor (1 in. steel)			Scale	Below 100	
Probe Number	1555	1555	Depth Scale (ft. in.)		10
Probe Dia. (in.)			Pen. Out (ft.)		10
Crystal Size (in.)			Reference Source (log)		
Probe Out (ft.)					
Reference Source (log)					

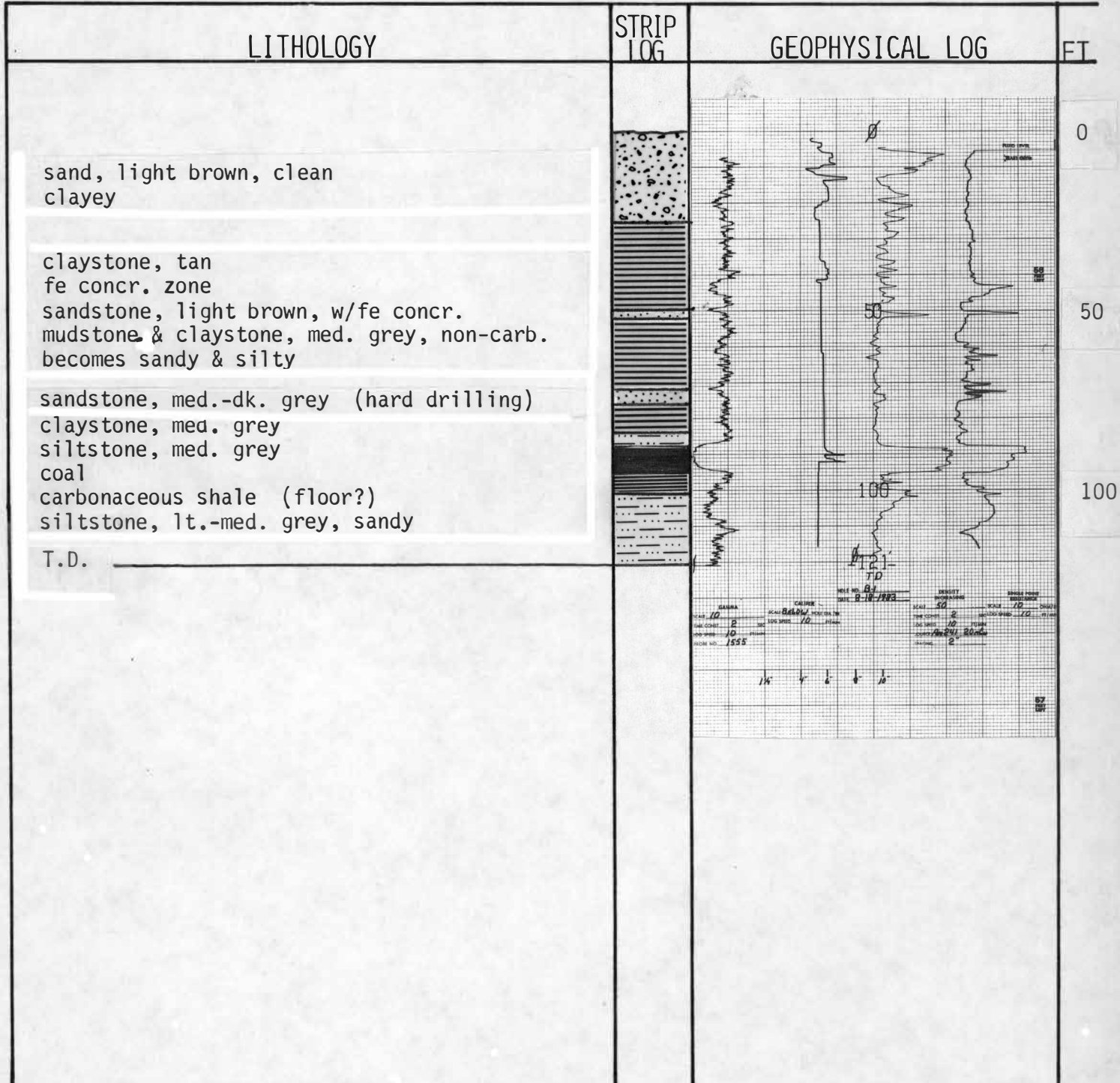

COLORADO GEOLOGICAL SURVEY
 TRI-TOWN SUBSIDENCE INVESTIGATION
 DRILL HOLE LOG

Hole No. B-2

Date Logged: Aug 18, 1983

Drilled Depth: 110

Logged Depth: 110

Drilling Medium: water

Section: 30

Township: 2N

Range: 67W

Elevation(Ft): 4961

RADIATION LOG			ELECTRIC LOG		
Gamma	Caliper	Resistivity	Resistivity	Scale	Depth
110	110		110		110
Range (ft. in.)	10 50		10		10
Counts Increasing to	→ 3		10 ³ Normal Resistivity (Ωm-ft.)		
Depth Scale (ft. in.)	10 10		10 ³ Normal Resistivity (Ωm-ft.)		
Logging Speed (ft. min.)	10 10		Logging Speed (ft. min.)		10
Time Constant(s)	2 2		Viscosity-Density		
Dead Time (μsec)			Pen. @ 1"V		
K-factor (LTD)			Pen. @ 1"V		
Water Factor (J in. hole)					
Caliper Factor (J in. steel)	1555 1550				
Probe Number					
Probe Dia. (in.)					
Circuit Scale (in.)					
Print Out (ft.)					
Reference Source (cps.)					

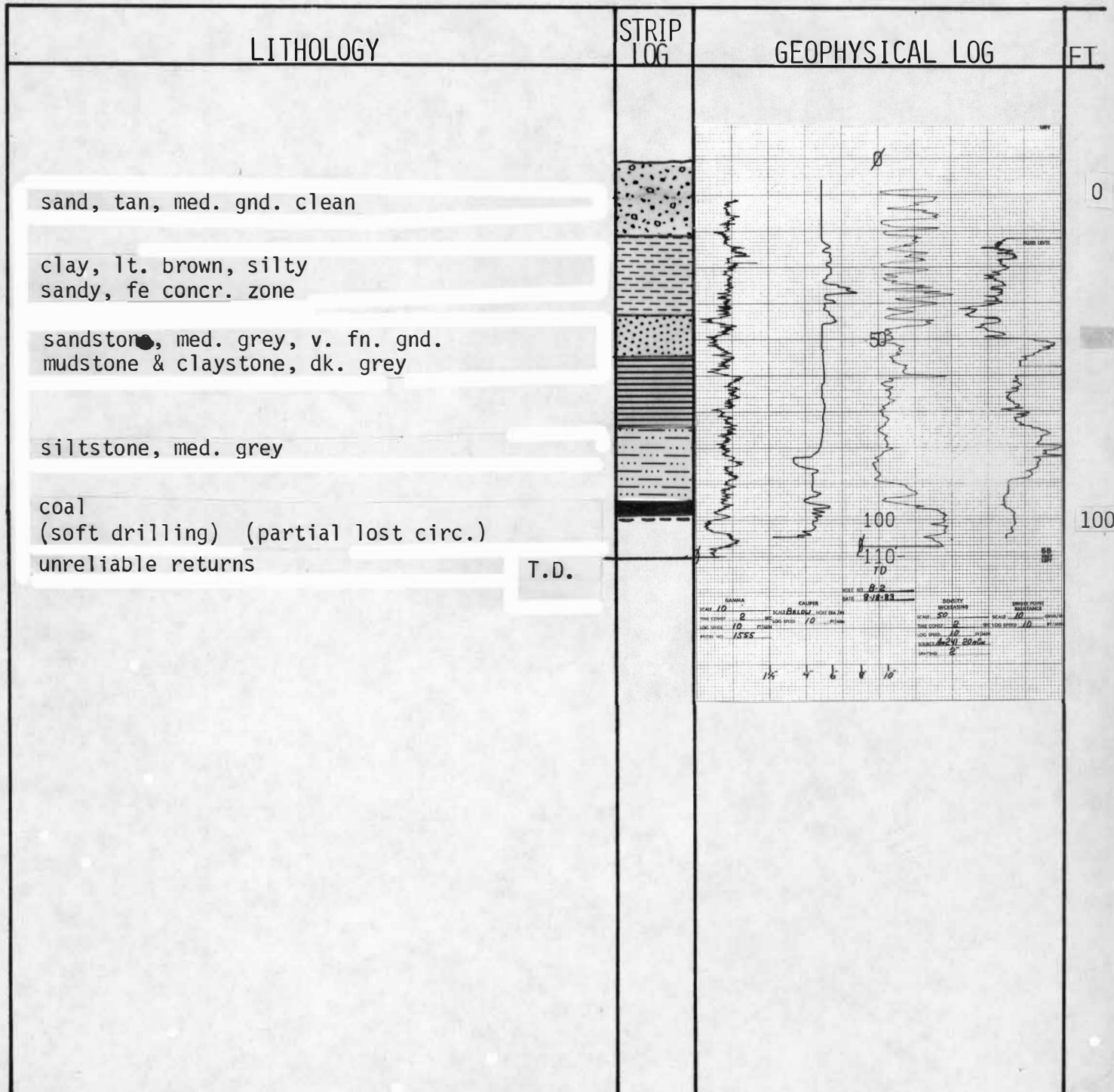

COLORADO GEOLOGICAL SURVEY
 TRI-TOWN SUBSIDENCE INVESTIGATION
 DRILL HOLE LOG

Hole No. B-3
 Date Logged: Aug 18, 1983
 Drilled Depth: 120
 Logged Depth: 120
 Drilling Medium: water

Section: 30
 Township: 2N
 Range: 67W
 Elevation (Ft.): 4966

RADIATION LOG			ELECTRIC LOG		
Gamma	Density	Neutron	Logged Depth (ft.)	Resistance Scale (ohm-ft.)	Scale (ohm-in.)
120	180		120	10	
Range Scale (in.)	10	50	5 ft. Scale (inches)	50	Normal Resistivity (ohm-in.)
Counting Interval (ft.)			5 ft. Normal Resistivity (ohm-in.)		Logging Speed (ft./min.)
Depth Scale (ft. in.)	10	10	Viscosity (centipoise)		Arm. @ T/F
Logging Speed (ft./min.)	10	10	Arm. @ T/F		Princ. @ T/F
Time Constant (min.)	2	2			
Dead Time (µsec.)					
K-factor (x10 ³)					
Water Factor (1 in hole)					
Casing Factor (1 in steel)					
Probe Number:	1555	1550			
Probe Dia. (in.)					
Crystal Size (in.)					
Probe Dia. (ft.)					
Reference Source (cps)					

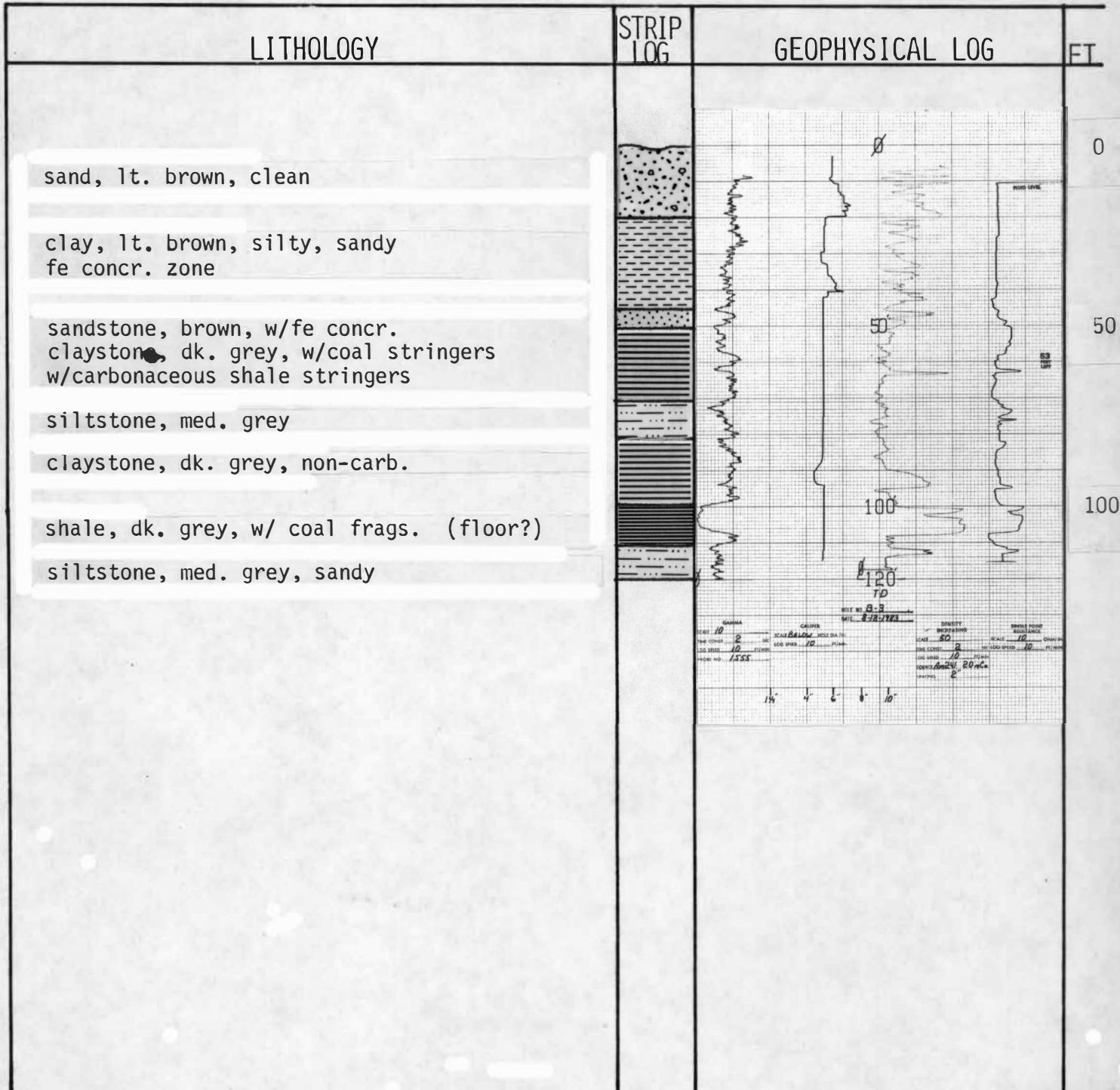

COLORADO GEOLOGICAL SURVEY
 TRI-TOWN SUBSIDENCE INVESTIGATION
 DRILL HOLE LOG

Hole No. B-4

Date Logged: Aug 18, 1983

Drilled Depth: 107

Logged Depth: 107

Drilling Medium: water

Section: 30

Township: 2N

Range: 67W

Elevation(Ft): 4966

RADIATION LOG			ELECTRIC LOG		
Gamma	Density	Neutron	Logged Depth (ft.)	Resistance Scale (Ω-in.)	S.P. Scale (mV/m)
Logged Depth (ft.)	107	107			
Repeat Interval (ft.)					
Range (ft. in.)	10	50			
Counts Increasing to	→	→			
Depth Scale (ft. in.)	10	10			
Logging Speed (ft./min.)	10	10			
Time Constant(s)	2	2			
Dead Time (μsec.)					
K-Factor (d/cu.)					
Water Factor (1 in hole)					
Calomel Factor (1 in steel)					
Probe Number	1555	1550			
Probe Dia. (in.)					
Crystal Size (in.)					
Probe Dia. (ft. in.)					
Reference Source (ppm)					

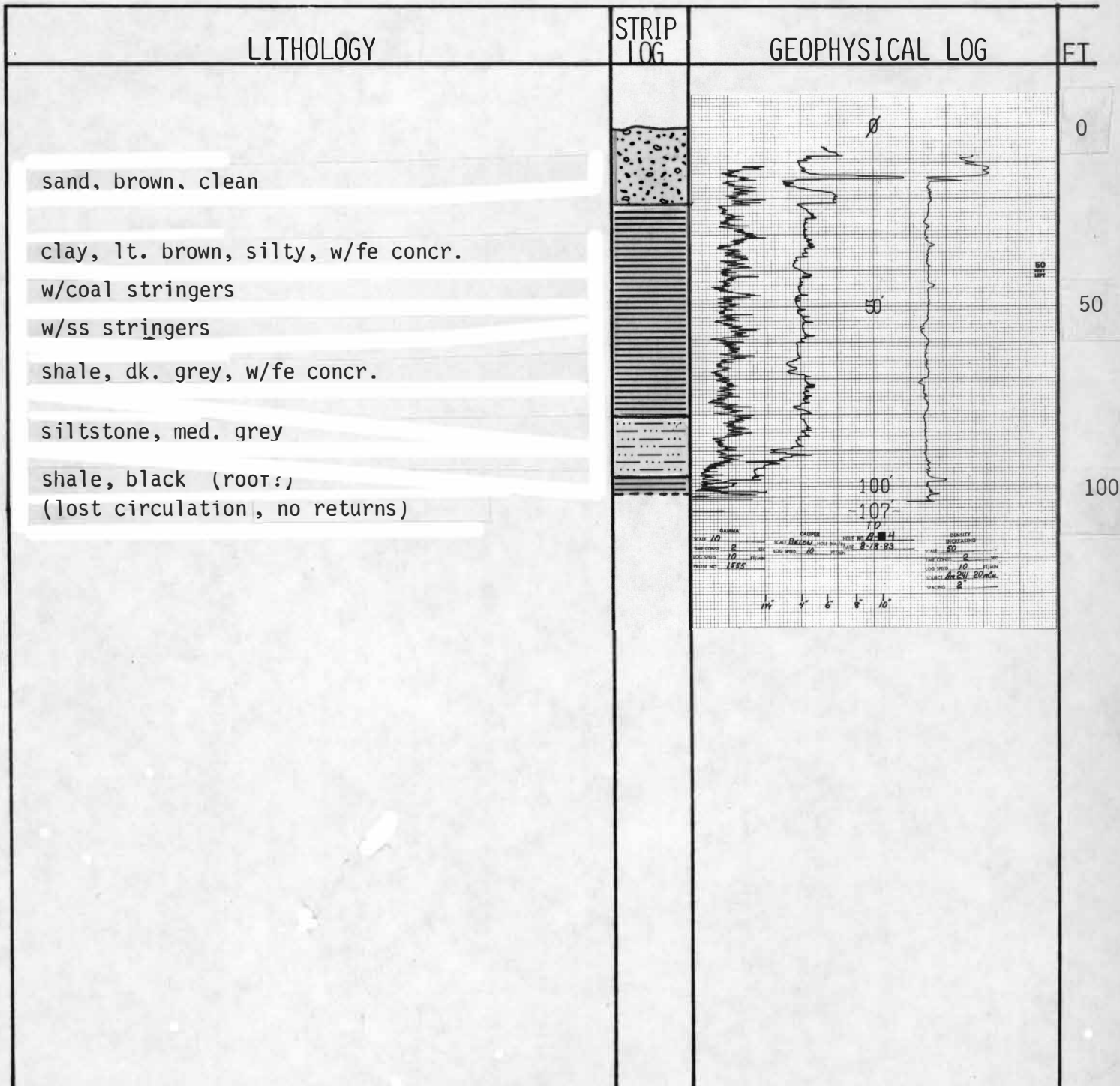

COLORADO GEOLOGICAL SURVEY
TRI-TOWN SUBSIDENCE INVESTIGATION
DRILL HOLE LOG

Hole No. B-5

Date Logged: Aug 18, 1983

Drilled Depth: 106

Logged Depth: 93

Drilling Medium: water

Section: 30

Township: 2N

Range: 67W

Elevation(Ft): 4971

RADIATION LOG			ELECTRIC LOG		
Gamma	Deriva	Neutron			
Logged Depth (ft.)	93	93	Logged Depth (ft.)	93	
Return Interval (ft.)			Resistance Scale (ft.in.)	10	
Range (cps/in.)	10	50	S. P. Scale (mv/in.)		
Counts Increasing to:			10 ³ Normal Resistivity (ft.in.)		
Depth Scale (ft.in.)	10	10	10 ⁴ Normal Resistivity (ft.in.)		
Logging Speed (ft./min.)	10	10	Logging Speed (ft./min.)	10	
Time Constant(s)	2	2	Velocity Density		
Dead Time (sec.)			Rm @ 10'		
K Factor (x10 ³)			Rm @ 10'		
Water Factor () in. hole					
Casing Factor () in. steel					
Probe Number	1558	1580	LOG		
Probe Dia. (in.)			Logged Depth (ft.)	93	
Crystal Size (in.)			Scale	10	
Probe Out (ft.)			Depth Scale (ft.in.)	10	
Reference Source (cps.)			Logging Speed (ft./min.)	10	

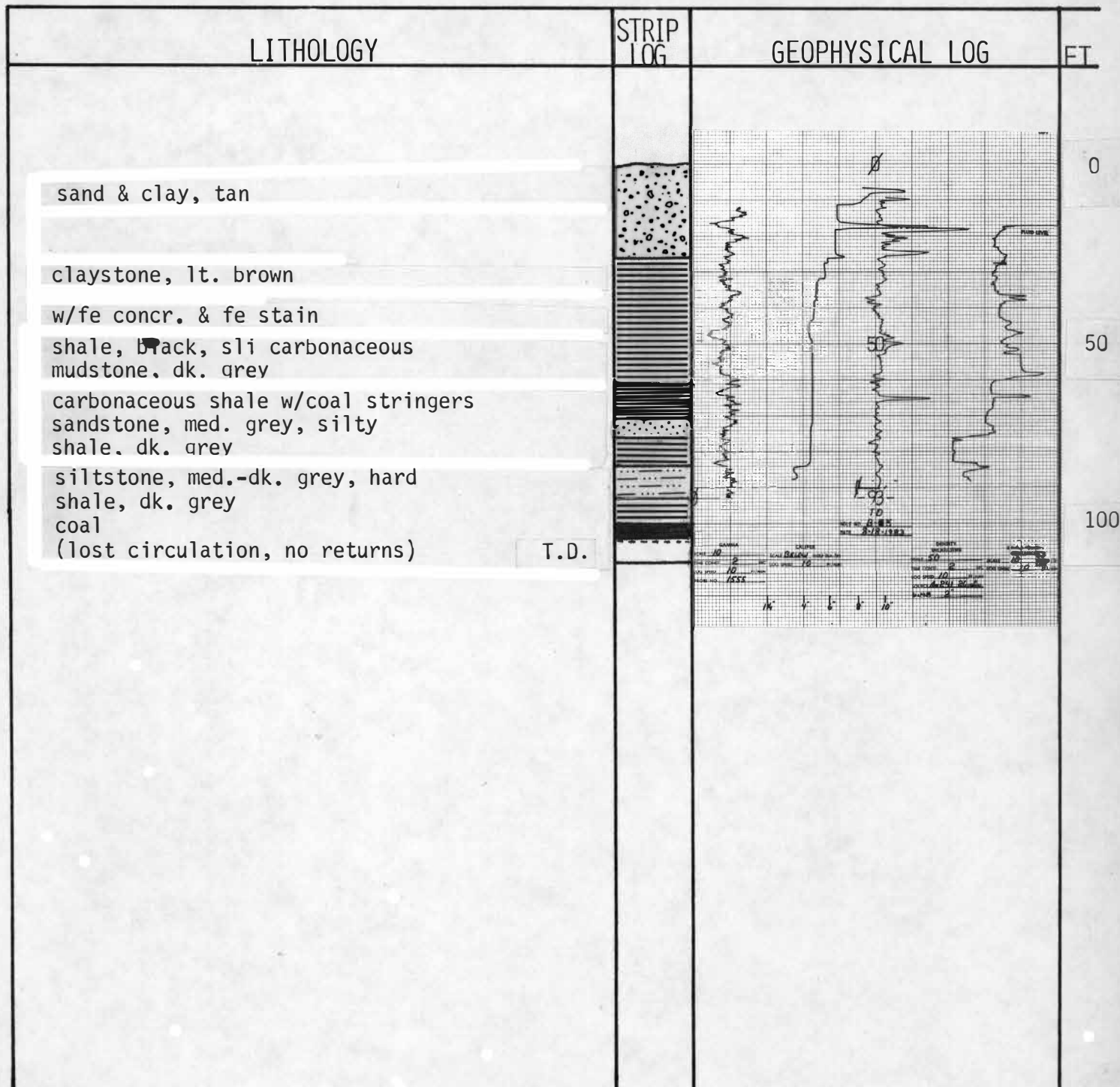

COLORADO GEOLOGICAL SURVEY
 TRI-TOWN SUBSIDENCE INVESTIGATION
 DRILL HOLE LOG

Hole No. F-1

Date Logged: Aug 23, 1983

Drilled Depth: 201

Logged Depth: 201

Drilling Medium: water

Section: 31

Township: 2N

Range: 67W

Elevation(Ft): 4975

RADIATION LOG		ELECTRIC LOG	
Logged Depth (ft.)	201	Logged Depth (ft.)	201
Run-in Interval (ft.)		Resistance Scale (Ω-in.)	10
Range (cps/in.)	10 50	% Scale (ohm-in.)	
Counts increasing to	10 50	10" Normal Resistivity (Ω-in.)	
Depth Scale (ft./in.)	10 10	64" Normal Resistivity (Ω-in.)	
Logging Speed (ft./min.)	10 10	Logging Speed (ft./min.)	10
Time Constant (sec.)	2 10	Viscosity-Density	
Dead Time (µsec.)	2 10	Arm. @ 1" / 1"	
K-factor (αD ²)		Arm. @ 1" / 1"	
Water Factor () in. hole		Arm. @ 1" / 1"	
Casing Factor () in. steel			
Probe Number	1555 1550		
Probe Dia. (in.)			
Crystal Size (in.)			
Probe Unit (ft.)			
Reference Source (cps.)			

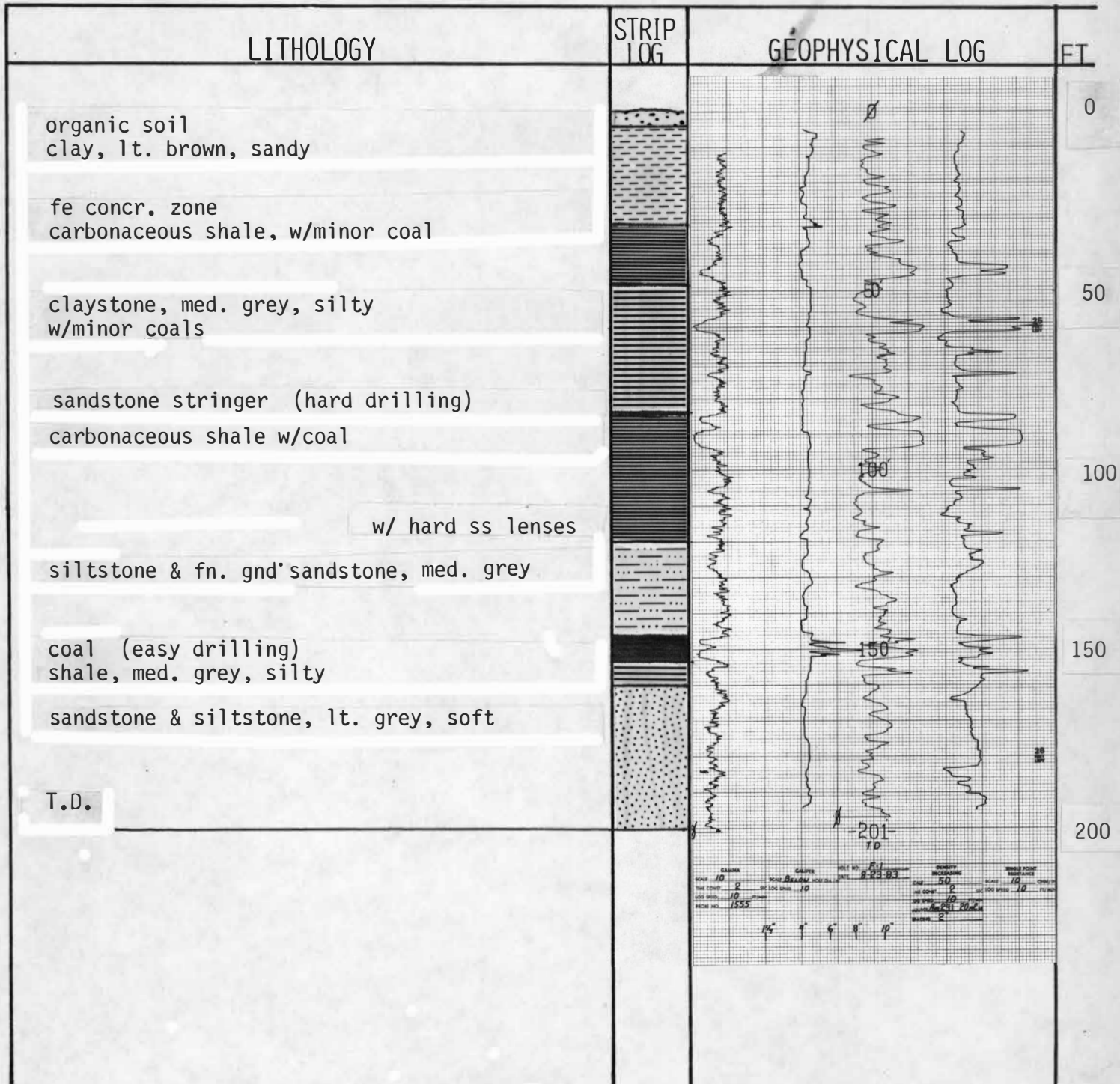

COLORADO GEOLOGICAL SURVEY
 TRI-TOWN SUBSIDENCE INVESTIGATION
 DRILL HOLE LOG

Hole No. F-2

Date Logged: Aug 23, 1983

Drilled Depth: 181

Logged Depth: 181

Drilling Medium: water

Section: 31

Township: 2N

Range: 67W

Elevation(Ft): 4975

RADIATION LOG		ELECTRIC LOG	
Gamma	Count	Scale	Scale
1.81	1.81	1.81	1.81
Range Log (ft.)		Resistance Scale (ohm.)	1.0
Counting Interval (ft.)		C.P. Scale (cpm/ft.)	
Counting Rate (cpm)	50	10" Normal Resistivity (ohm/ft.)	
Counting Interval (ft.)	1.0	60" Normal Resistivity (ohm/ft.)	
Logging Speed (ft./min.)	1.0	Logging Speed (ft./min.)	1.0
Time Constant (sec)	2	Viscosity-Density	
Dead Time (sec)	2	Temp. @ 1"	
K-factor (10 ³)		Temp. @ 10"	
Water Factor (1 in. hole)		Temp. @ 10'	
Counting Factor (1 in. hole)			
Probe Number	1555/1550		
Probe Dia. (in.)			
Crystal Size (in.)			
Probe Out. (ft.)			
Reference Source (ppm)			

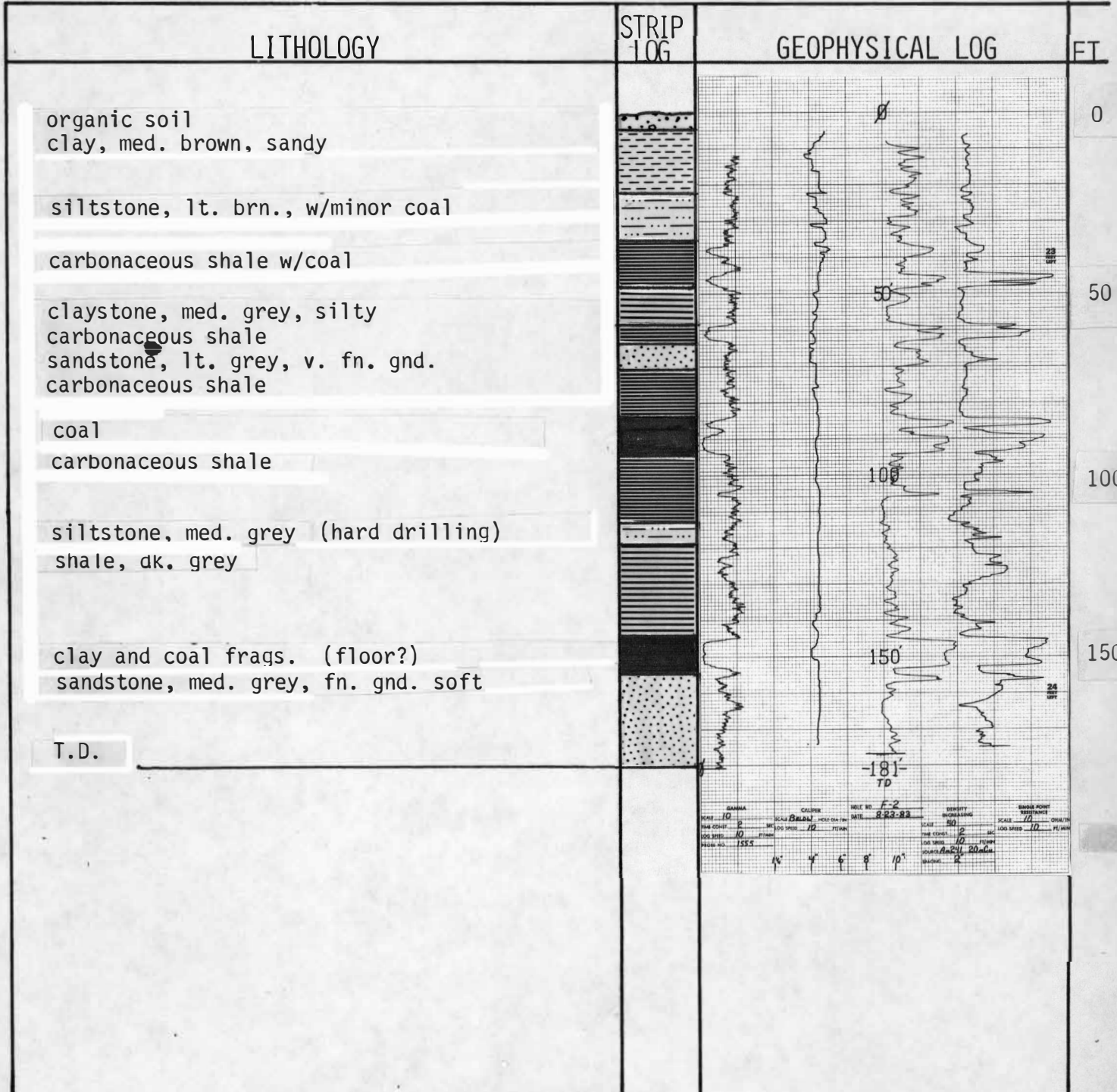

COLORADO GEOLOGICAL SURVEY
 TRI-TOWN SUBSIDENCE INVESTIGATION
 DRILL HOLE LOG

Hole No. F-3

Date Logged: Aug 23, 1983

Drilled Depth: 181

Logged Depth: 181

Drilling Medium: water

Section: 31

Township: 2N

Range: 67W

Elevation(Ft): 4977

RADIATION LOG			ELECTRIC LOG		
Logged Depth (ft.)	181	181	Logged Depth (ft.)	181	
Run Interval (ft.)			Resistance Scale (ohm.)	10	
Range (ohm.)	10	50	5-F Scale (mohm.)		
Counts Increasing to:	10	10	10-F Normal Resistivity (ohm-in.)		
Depth Scale (ft./in.)	10	10	Logging Speed (ft./min.)	10	
Logging Speed (ft./min.)	10	10	Viscosity-Density		
Time (Conductance)	10	10	Phi @ 17F		
Dead Time (muSec)			Phi @ 17F		
K-factor (x10 ³)			Phi @ 17F		
Water Factor (1 in. hole)			LOG		
Casing Factor (1 in. steel)			Logged Depth (ft.)	181	
Probe Number	1555	1550	Scale	Below Log	
Probe Dia. (in.)			Depth Scale (ft./in.)	10	
Crystal (Siemens)			Logging Speed (ft./min.)	10	
Press. Out. (ft.)					
Reference (Source Log)					

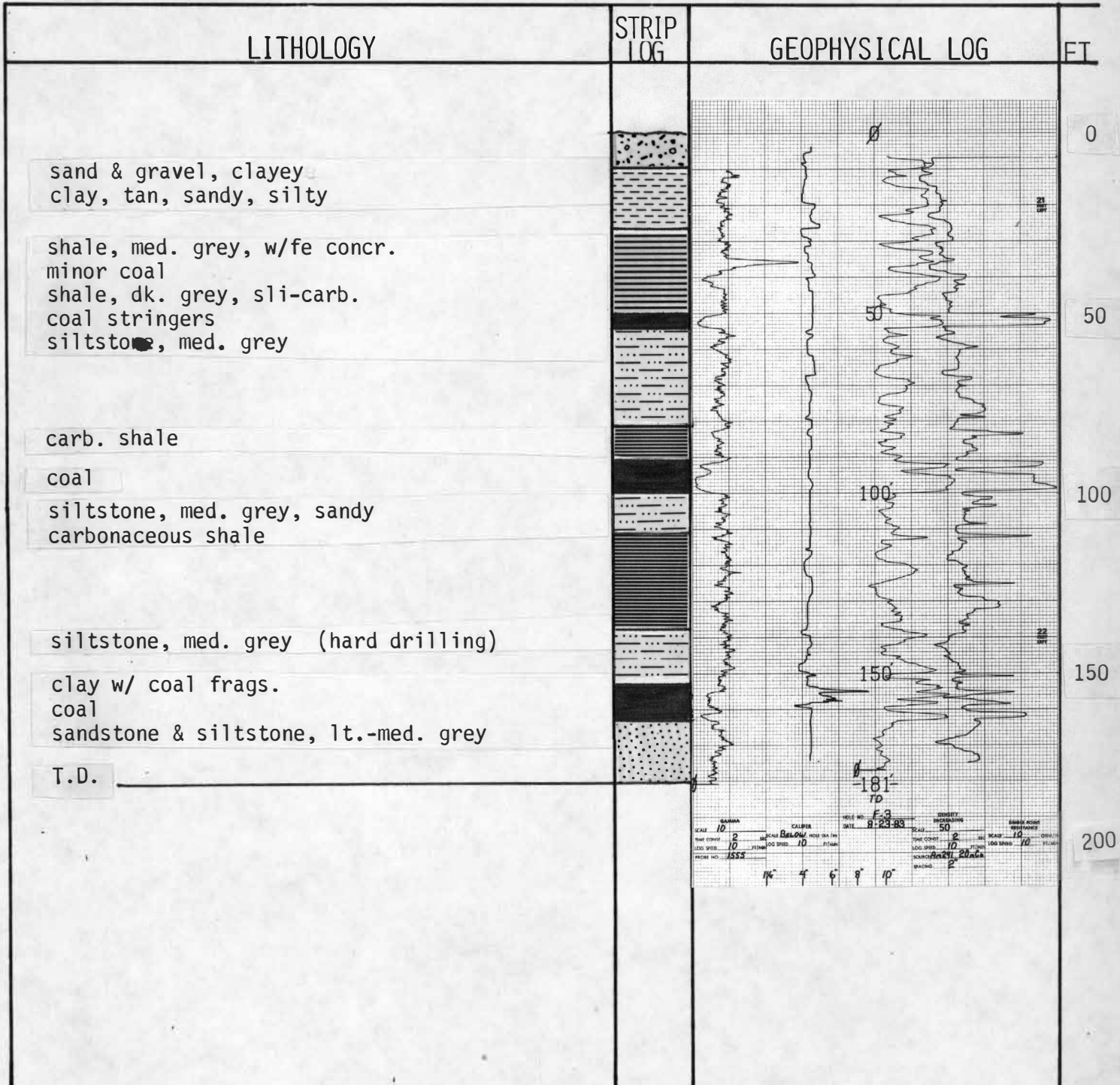

COLORADO GEOLOGICAL SURVEY
TRI-TOWN SUBSIDENCE INVESTIGATION
DRILL HOLE LOG

Hole No. F-4

Date Logged: Aug 23, 1983

Drilled Depth: 181

Logged Depth: 181

Drilling Medium: water

Section: 31

Township: 2N

Range: 67W

Elevation(Ft): 4977

RADIATION LOG			ELECTRIC LOG		
Depth (ft.)	Count	Source	Depth (ft.)	Scale	Unit
181	181				
Range (ft. in.)			Resistance Scale (kΩ in.)		10
Counting Interval (min.)	10	10	5 2" Scale (min.)		
Depth Scale (ft. in.)			10" Normal Resistivity (Ω-in.)		
Logging Speed (ft. min.)	10	10	54" Normal Resistivity (Ω-in.)		
Time Constant(s)	10	10	Logging Speed (ft. min.)		10
Dead Time (μsec)	10	10	Viscosity Density		
Water Factor (1 in. hole)			Pen. @ 1" (in.)		
Gamma Factor (1 in. hole)			Pen. @ 1" (ft.)		
Probe Number	1500	1500	Pen. @ 1" (ft.)		
Probe Dia. (in.)			LOG		
Probe Size (in.)			Logged Depth (ft.)	181	
Probe Chk. (ft.)			Scale	Below Log	
Reference Source (log)			Depth Scale (ft. in.)	10	
			Logging Speed (ft. min.)	10	

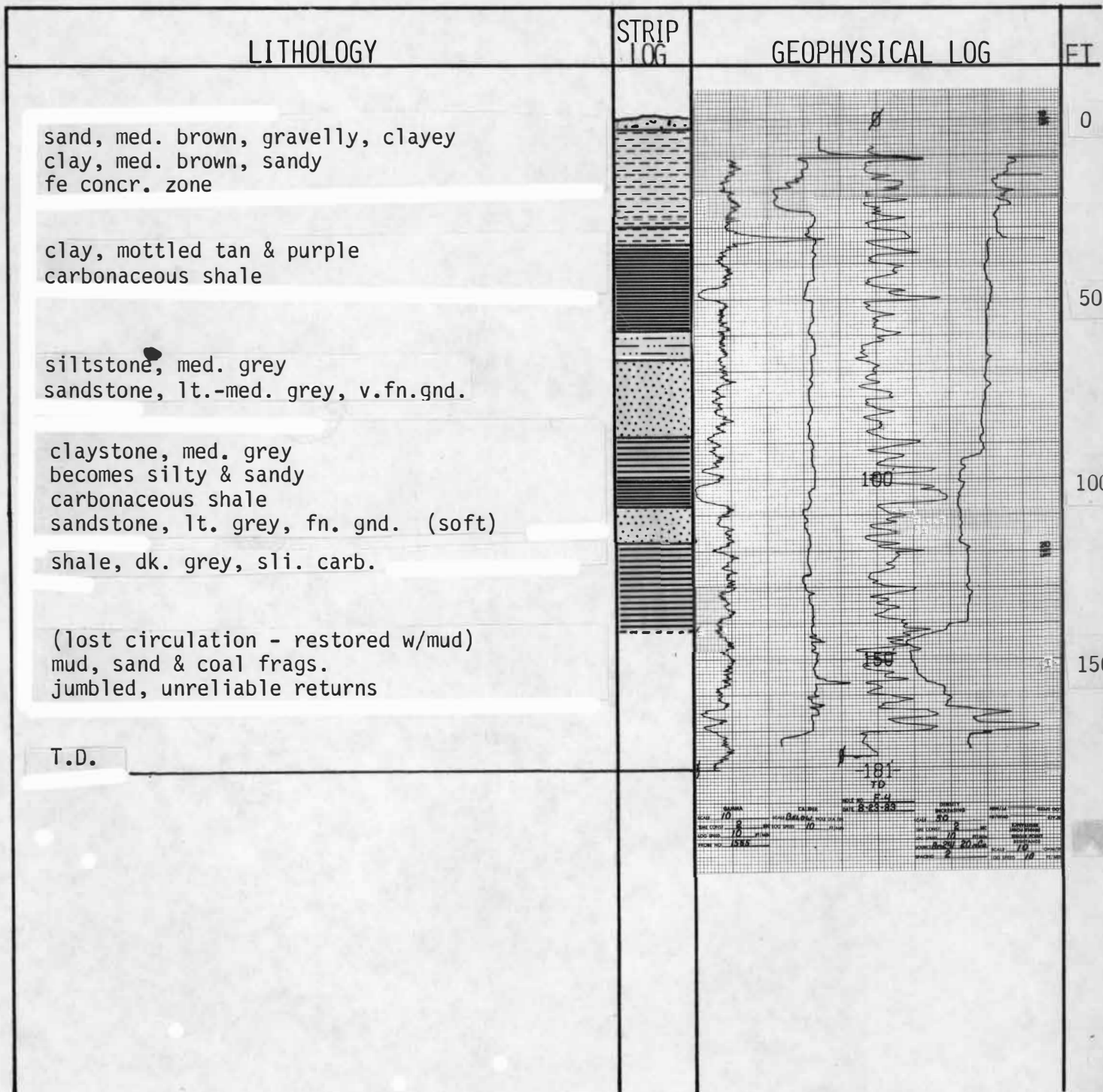

COLORADO GEOLOGICAL SURVEY
 TRI-TOWN SUBSIDENCE INVESTIGATION
 DRILL HOLE LOG

Hole No. F-5

Date Logged: Aug 23, 1983

Drilled Depth: 181

Logged Depth: 181

Drilling Medium: water

Section: 31

Township: 2N

Range: 67W

Elevation (Ft): 4978

RADIATION LOG			ELECTRIC LOG		
Logged Depth (ft.)	Gamma	Density	Logged Depth (ft.)	Resistance Scale (Ohm-in)	SP Scale (mV/in)
181	181		181	10	
Range (logs/in)	10	50	SP Scale (mV/in)		10
Counting Interval (min)			SP Normal Resistivity (Ohm-in)		
Depth Scale (ft./in)	10	10	SP Normal Resistivity (Ohm-in)		10
Logging Speed (ft./min)	10	10	Logging Speed (ft./min)		
Time Constant (sec)	2	2	SP Normal Resistivity (Ohm-in)		
Dead Time (sec)			Logging Speed (ft./min)		
Factor (x10 ³)			SP Normal Resistivity (Ohm-in)		
Water Factor (1 in hole)			SP Normal Resistivity (Ohm-in)		
Counting Factor (1 in steel)			SP Normal Resistivity (Ohm-in)		
Probe Dia. (in)	1.555	1.550	SP Normal Resistivity (Ohm-in)		
Counting Rate (cts/min)			SP Normal Resistivity (Ohm-in)		
Probe Out (ft.)			SP Normal Resistivity (Ohm-in)		
Reference Source (logs)			SP Normal Resistivity (Ohm-in)		

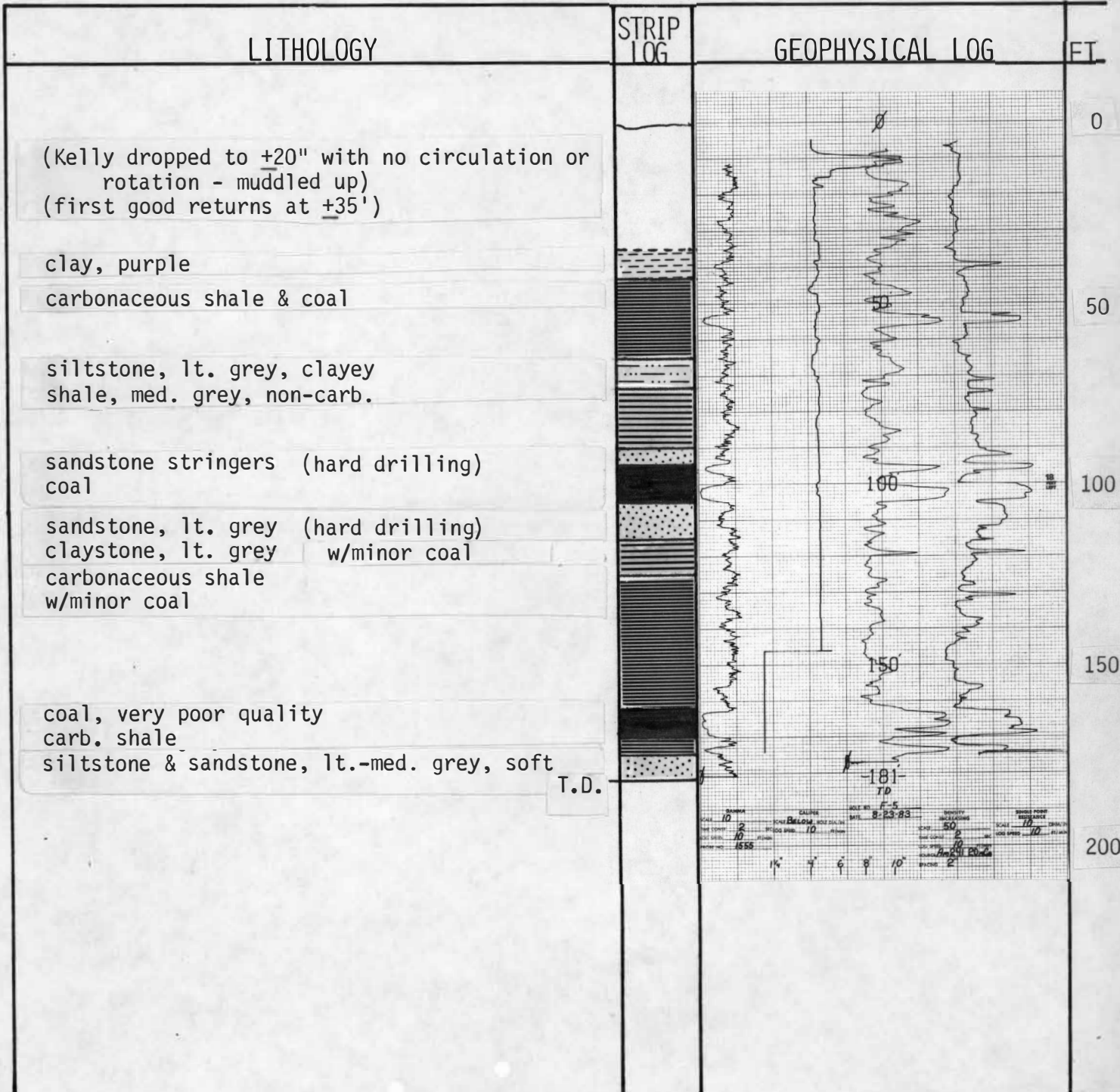

COLORADO GEOLOGICAL SURVEY
 TRI-TOWN SUBSIDENCE INVESTIGATION
 DRILL HOLE LOG

Hole No. J-1

Date Logged: Aug 29, 1983

Drilled Depth: 263

Logged Depth: 263

Drilling Medium: water

Section: 6

Township: 1N

Range: 67W

Elevation(Ft): 5027

RADIATION LOG			ELECTRIC LOG		
Logged Depth (ft.)	263	263	Logged Depth (ft.)	263	263
Run Interval (ft.)			Resistance Scale (ohm-ft.)	10	10
Range (cpm/in.)	10	50	S.P. Scale (mv/in.)		
Counts Increasing to	→	→	SP Normal Resistivity (ohm-ft.)		
Depth Scale (ft./in.)	10	10	SP Normal Resistivity (ohm-ft.)		
Logging Speed (ft./min.)	10	10	Logging Speed (ft./min.)	10	10
Time Constant(sec)	2	2	Viscosity-Density		
Case Time Log(s)			Pen. @ 1 ft.		
K-factor (in ² /cpm)			Pen. @ 1 ft.		
Water Factor (in hole)					
Counting Factor (10,000)	1000	1000			
Probe Number			Logged Depth (ft.)	263	263
Probe Dia. (in.)			Scale	10	10
Crystal Size (in.)			Depth Scale (ft./in.)	10	10
Print Out (ft.)			Logging Speed (ft./min.)	10	10
Reference Source (cpm)					

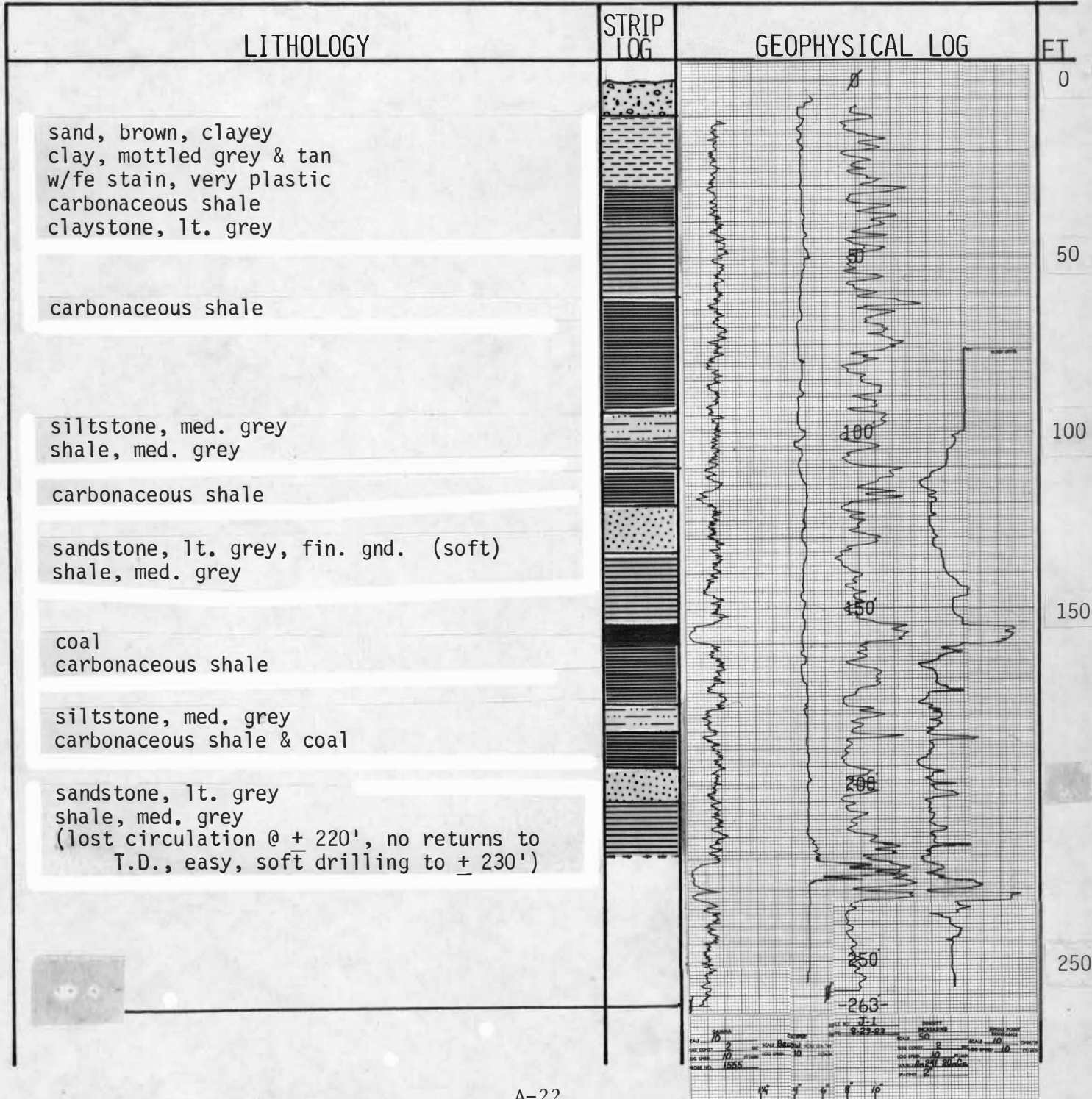

COLORADO GEOLOGICAL SURVEY
 TRI-TOWN SUBSIDENCE INVESTIGATION
 DRILL HOLE LOG

Hole No. J-2

Date Logged: Aug 30, 1983

Drilled Depth: 262

Logged Depth: 262

Drilling Medium: water

Section: 6

Township: 1N

Range: 67W

Elevation(Ft): 5030

RADIATION LOG			ELECTRIC LOG		
Logged Depth (ft.)	262		Logged Depth (ft.)	262	
Strat. Interval (ft.)			Resistance Scale (ohm.)	10	
Range (logs, ft.)	10	50	S.P. Scale (mv/in.)		
Counts increasing to			15° Normal Resistivity (ohm-in.)		
Depth Scale (ft., in.)	10	10	64° Normal Resistivity (ohm-in.)		
Logging Speed (ft./min.)	10	10	Logging Speed (ft./min.)	10	
Time Consumption (min.)	2	2	Velocity Density		
Dead Time (secs.)			Rm. @ 1°F		
K-factor (x10 ³)			Rm. @ 75°F		
Water Factor () in. hole			Rm. @ 1°F		
Casing Factor () in. steel					
Probe Number	1555	1550	LOG		
Probe Dia. (in.)			Logged Depth (ft.)	262	
Crystal Size (in.)			Scale	Below Log	
Probe Dia. (ft.)			Depth Scale (ft., in.)	10	
Reference Source (logs.)			Logging Speed (ft./min.)	10	

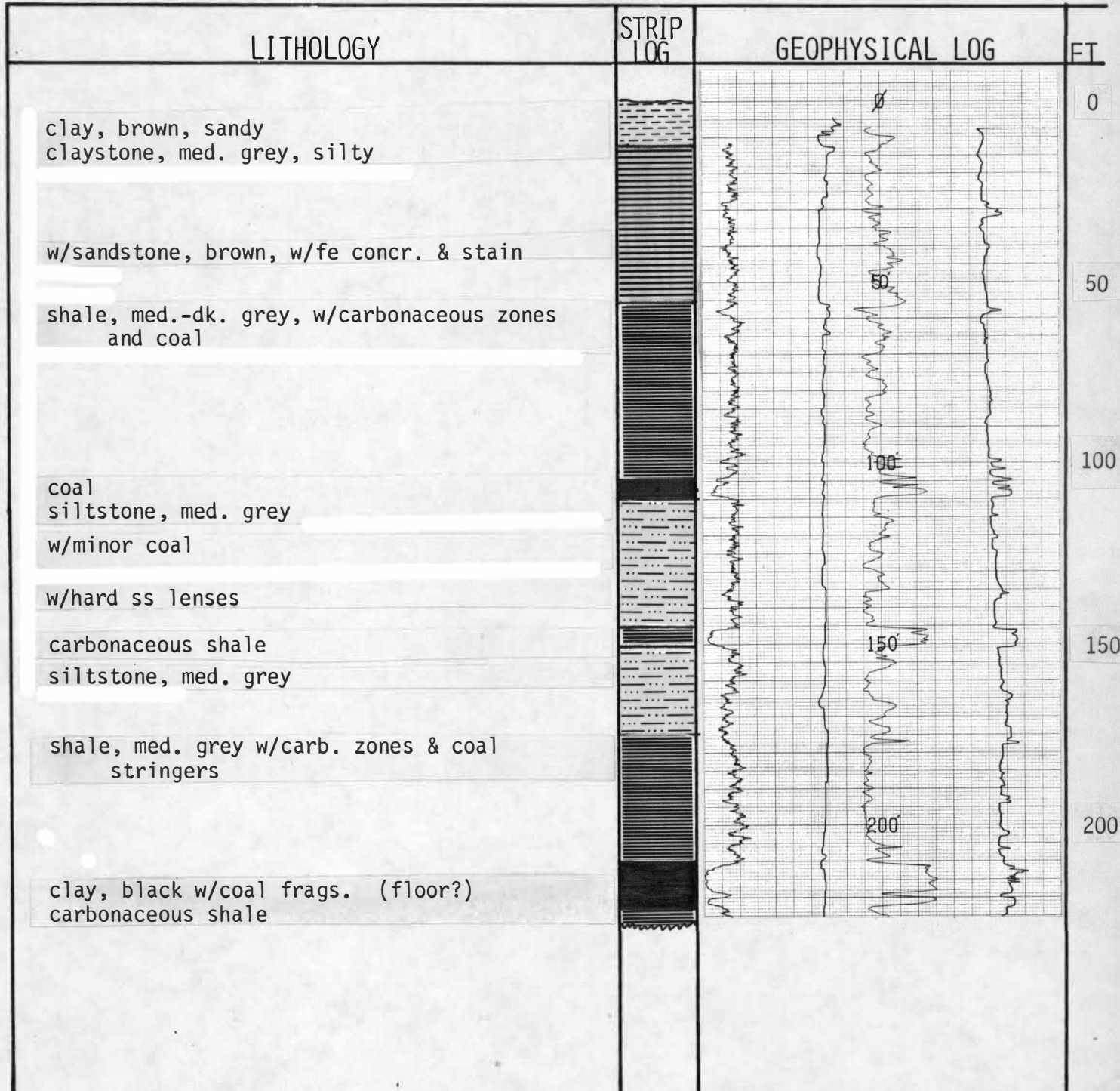

COLORADO GEOLOGICAL SURVEY
 TRI-TOWN SUBSIDENCE INVESTIGATION
 DRILL HOLE LOG

Hole No. J-4

Date Logged Aug 30, 1983

Drilled Depth: 236

Logged Depth: 236

Drilling Medium: water

Section: 6

Township: 2N

Range: 67W

Elevation(Ft): 5035

RADIATION LOG				ELECTRIC LOG			
Logged Depth (ft.)	236	236		Logged Depth (ft.)	236		
Run-in Interval (ft.)				Resistance Scale (ohm-ft.)	10		
Range (cps/in.)	10	50		S.P. Scale (mv/in.)			
Counts Increasing to	10	10		SP Normal Resistivity (ohm-ft.)			
Depth Scale (ft./in.)	10	10		SP Normal Resistivity (ohm-ft.)			
Logging Speed (ft./min.)	10	10		Logging Speed (ft./min.)	10		
Time Constant(s)	2	2		Velocity-Density			
Dead Time (sec)	2	2		Pen. @ 1" F			
k-factor (x10 ³)				Pen. @ 1" F			
Water Factor (1 in. hole)				LOG			
Casing Factor (1 in. steel)				Logged Depth (ft.)	236		
Probe Number	1654	1700		Scale	10		
Probe Dia. (in.)				Depth Scale (ft./in.)	10		
Crystal Form (in.)				Logging Speed (ft./min.)	10		
Probe Out (ft.)							
Reference Source (cps)							

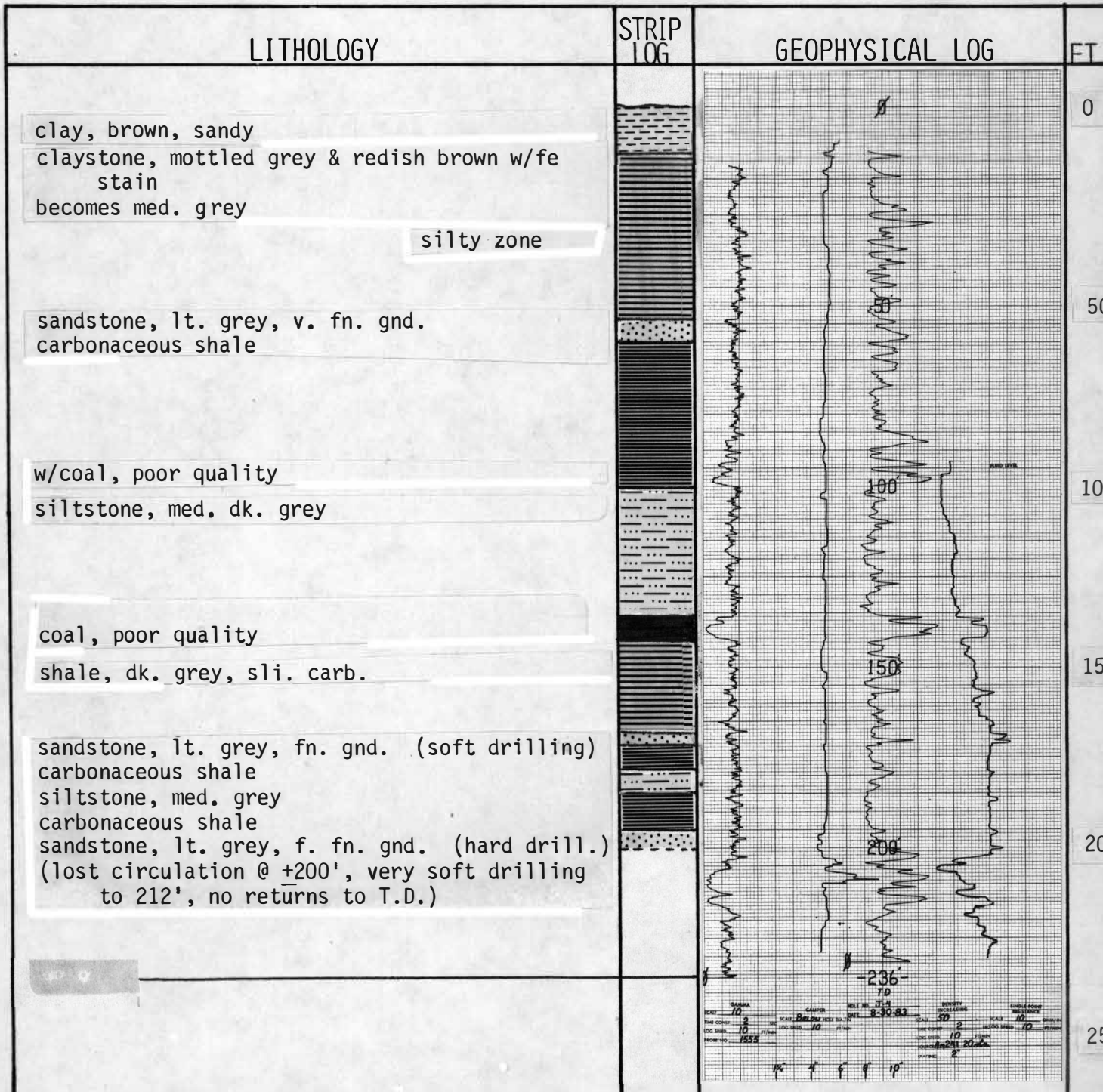

COLORADO GEOLOGICAL SURVEY
 TRI-TOWN SUBSIDENCE INVESTIGATION
 DRILL HOLE LOG

Hole No. M-2

Date Logged: Sept 7, 1983

Drilled Depth: 363

Logged Depth: 363

Drilling Medium: water

Section: 6

Township: 2N

Range: 67W

Elevation (Ft): 5052

GAMMA LOG		ELECTRIC LOG	
Logged Depth (ft.)	363 354	Logged Depth (ft.)	352 5
Run-in Interval (ft.)		Resistance Scale (ft/in.)	10
Range (cps/in.)	10 50	S.P. Scale (mV/in.)	
Counts increasing for	→ →	10° Normal Resistivity (ft/in.)	
Depth Scale (ft./in.)	10 10	50° Normal Resistivity (ft/in.)	
Logging Speed (ft./min.)	10 10	Logging Speed (ft./min.)	10
Time Constant(s)	2 2	Viscosity-Density	
Dead Time (sec.)		Rm. @ 1°F	
K-factor (x10 ³)		Rm. @ 7°F	
Water Factor (1 in. hole)		Rm. @ 17°F	
Casing Factor (1 in. steel)			
Probe Number	1555 1550	CALIPER LOG	
Probe Dia. (in.)		Logged Depth (ft.)	357
Circuit Scale (in.)		Scale	BELOW LOG
Print. Out (ft.)		Depth Scale (ft./in.)	10
Reference Source (cps)		Logging Speed (ft./min.)	10

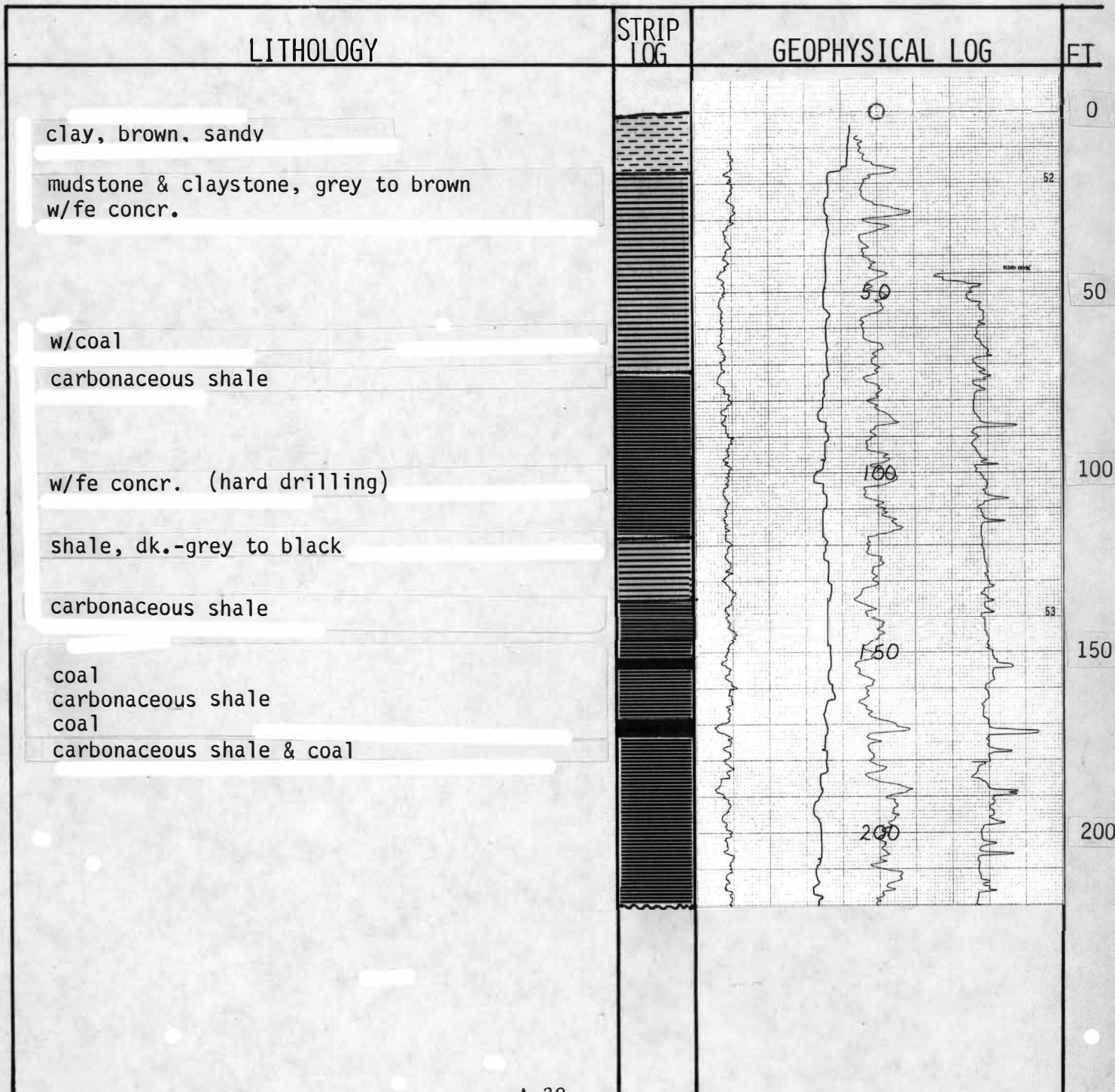

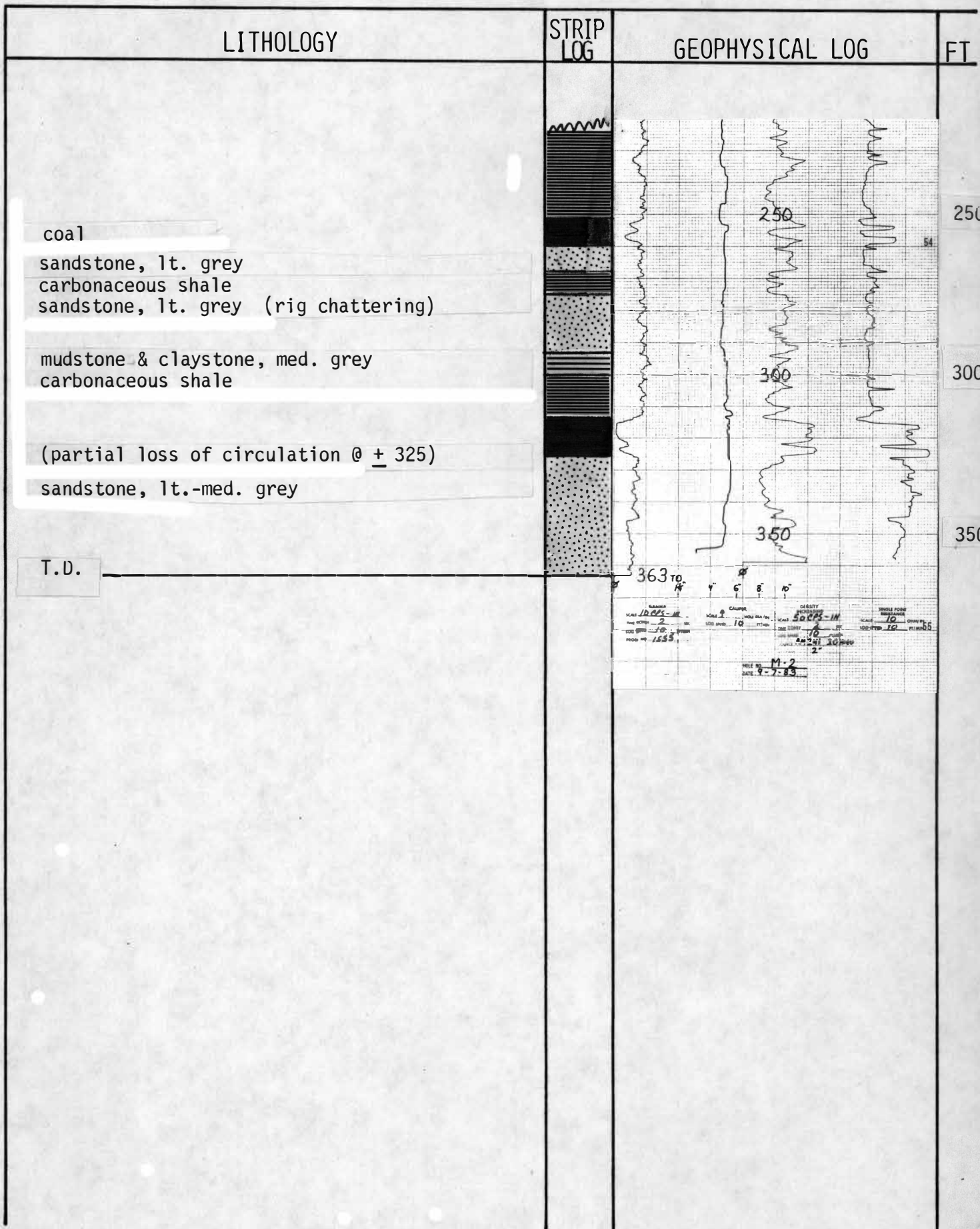

COLORADO GEOLOGICAL SURVEY
 TRI-TOWN SUBSIDENCE INVESTIGATION
 DRILL HOLE LOG

Hole No. M-3

Date Logged: Sept 2, 1983

Drilled Depth: 383

Logged Depth: 383

Drilling Medium: water

Section: 6

Township: 2N

Range: 67W

Elevation(Ft): 5051

RADIATION LOG			ELECTRIC LOG		
Logged Depth (ft.)	383	379	Logged Depth (ft.)	377.5	
Run-in Interval (ft.)			Resistance Scale (ft.in.)	10	
Range (ft.in.)	10	50	8" R Scale (ft.in.)		
Counts Increasing to			16" Normal Resistivity (ft.in.)		
Depth Scale (ft. in.)	10	10	84" Normal Resistivity (ft.in.)	10	
Logging Speed (ft. min.)	1.0	1.0	Logging Speed (ft. min.)		
Time Constant(sec.)	2	2	Viscosity-Density		
Depth Time Log(sec.)			Rm @ 7°F		
K-factor (x 10 ³)			Rm @ 77°F		
Water Factor () in. hole			Probe No.		
Casing Factor () in. steel			Scale	BELOW LOG	
Probe Number	1555/1550		Depth Scale (ft. in.)	10	
Probe Dia. (in.)			Logging Speed (ft. min.)	1.0	
Crystal Size (in.)			Reference Source (ft.in.)		
Probe Out (ft.)					
Reference Source (ft.in.)					

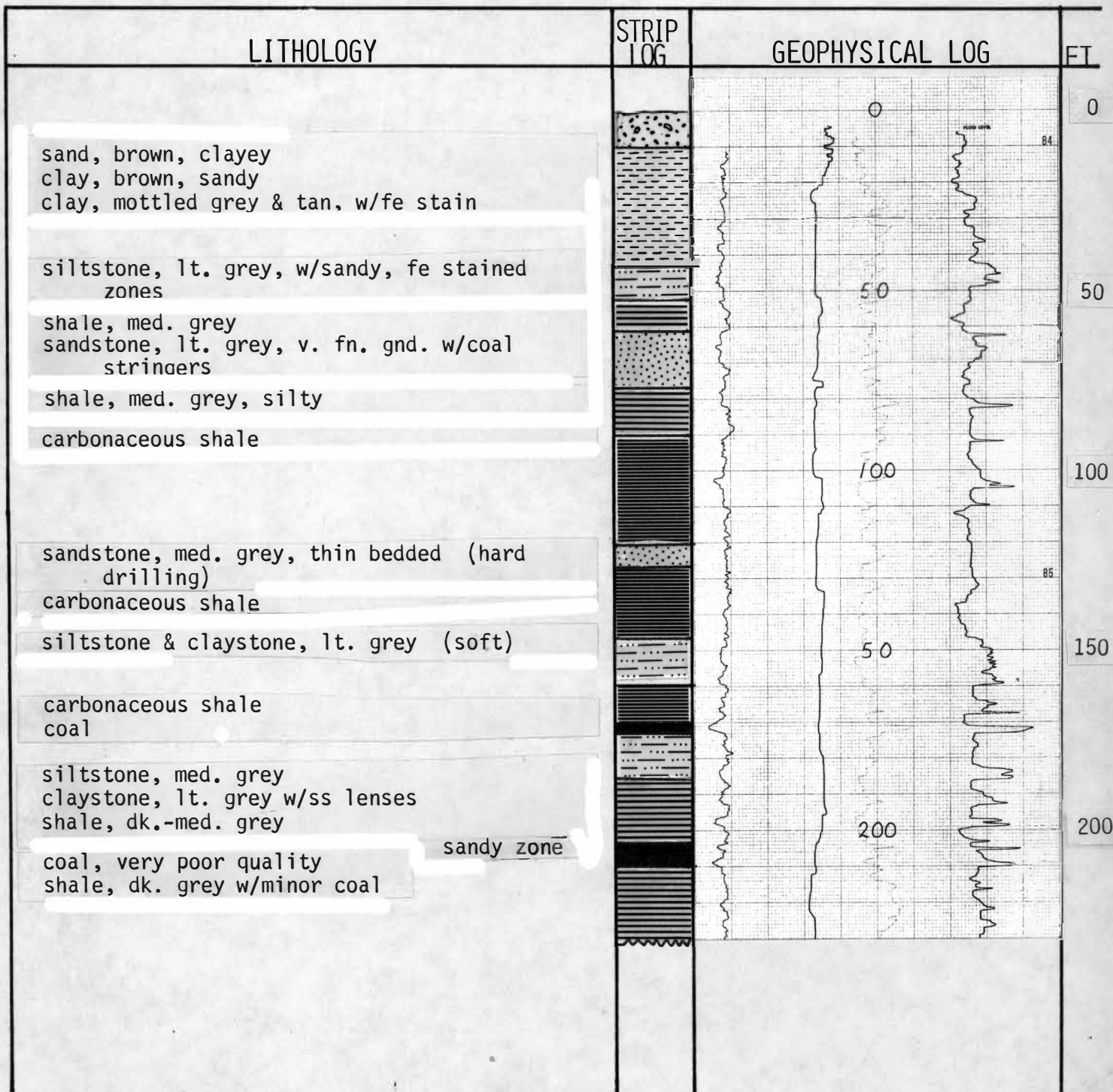

LITHOLOGY	STRIP LOG	GEOPHYSICAL LOG	FT
<p>siltstone, lt.-med. grey</p> <p>w/minor coal</p> <p>carbonaceous shale</p> <p>siltstone & sandstone, lt. grey</p> <p>shale, med.-dk. grey (loosing water, mudded up @ 310')</p> <p>coal</p> <p>siltstone, lt. grey</p> <p>shale, med. grey</p> <p>T.D.</p>			<p>250</p> <p>300</p> <p>350</p>

COLORADO GEOLOGICAL SURVEY
 TRI-TOWN SUBSIDENCE INVESTIGATION
 DRILL HOLE LOG

Hole No. M-5

Date Logged: Sept 6, 1983

Drilled Depth: 362

Logged Depth: 362

Drilling Medium: water

Section: 6

Township: 2N

Range: 67W

Elevation(Ft): 5055

GAMMA LOG		ELECTRIC LOG	
Logged Depth (ft.)	362 358	Logged Depth (ft.)	356.5
Run-in Interval (ft.)		Resistance Scale (ohm.)	10
Range (ohm. in.)	10 50	S. P. Scale (mv/in.)	
Counts Incrementing to	10 10	SP Normal Resistivity (ohm.in.)	
Depth Scale (ft. in.)	10 10	SP Normal Resistivity (ohm.in.)	10
Logging Speed (ft./min.)	10 10	Velocity (ft./min.)	
Time Constant(s)	1 2	Arm. @ 1" F	
Dead Time (secs.)		Arm. @ 1" F	
K Factor (x10 ³)		Probe No.	
Welder Factor () in. steel		Probe Dia. (in.)	
Casing Factor () in. steel		Crystal Size (in.)	
Probe Number	1555/550	Depth Scale (ft. in.)	10
Probe Dia. (in.)		Logging Speed (ft./min.)	10
Crystal Size (in.)			
Print Out (ft.)			
Reference Source (logs)			

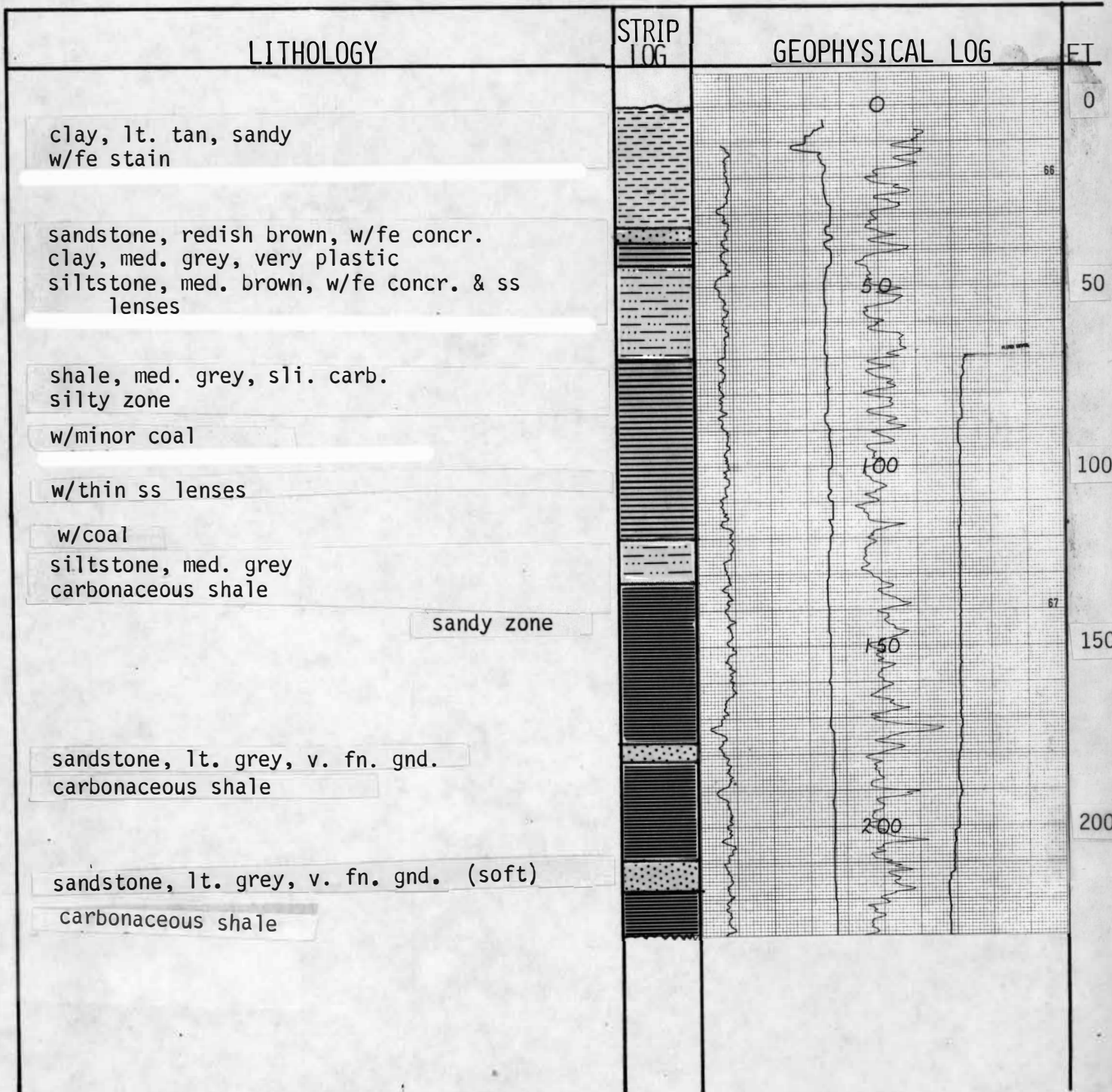

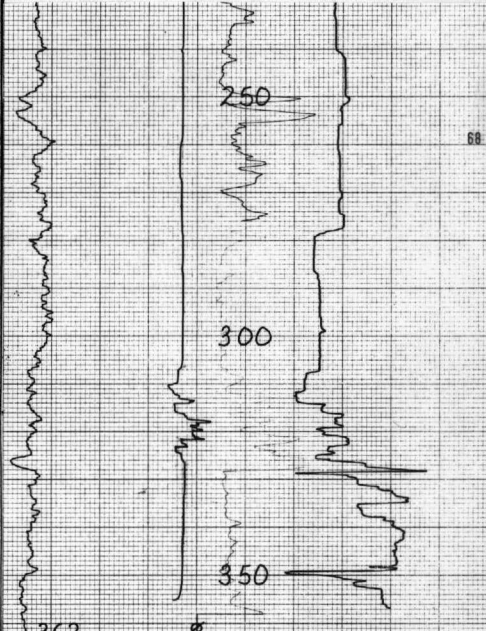
LITHOLOGY	STRIP LOG	GEOPHYSICAL LOG	FT
<p>carbonaceous shale</p> <p>w/minor coal, poor quality</p> <p>w/thin ss lenses</p> <p>(lost circulation @ + 315', no returns)</p> <p>T.D.</p>			<p>250</p> <p>300</p> <p>350</p>

362 TO

SCALE: 10 CPS-IN

LOG SPEED: 10 FT/SEC

MODEL NO: 1555

DATE: M-5

DATE: 9-6-82

COLORADO GEOLOGICAL SURVEY
TRI-TOWN SUBSIDENCE INVESTIGATION
DRILL HOLE LOG

Hole No. M-6

Date Logged: Sept 6, 1983

Drilled Depth: 340

Logged Depth: 292

Drilling Medium: water

Section: 6

Township: 2N

Range: 67W

Elevation(Ft): 5057

RADIATION LOG			ELECTRIC LOG		
Logged Depth (ft.)	292	288	Logged Depth (ft.)	286.5	
Run-in Interval (ft.)			Resistance Scale (ohm)	10	
Range (ft. in.)	10	50	S.P. Scale (mv/in.)		
Counts increasing to			10° Normal Resistivity (ohm-in.)		
Depth Scale (ft. in.)	10	10	64° Normal Resistivity (ohm-in.)		
Logging Speed (ft./min.)	10	10	Logging Speed (ft./min.)	10	
Time Constant(sec.)	2	2	Viscosity-Density		
Dead Time (sec.)			Rm @ 10'		
K-Factor (x10 ³)			Rm @ 10'		
Water Factor (1 in. hole)			Rm @ 10'		
Calibration Factor (1 in. steel)	1585	1550	Probe No.		
Probe Number			Logged Depth (ft.)	286	
Probe Dia. (in.)			Scale	BELOW LOG	
Crystal Size (in.)			Depth Scale (ft. in.)	10	
Print Out (ft.)			Logging Speed (ft./min.)	10	
Reference Source (ppm.)					

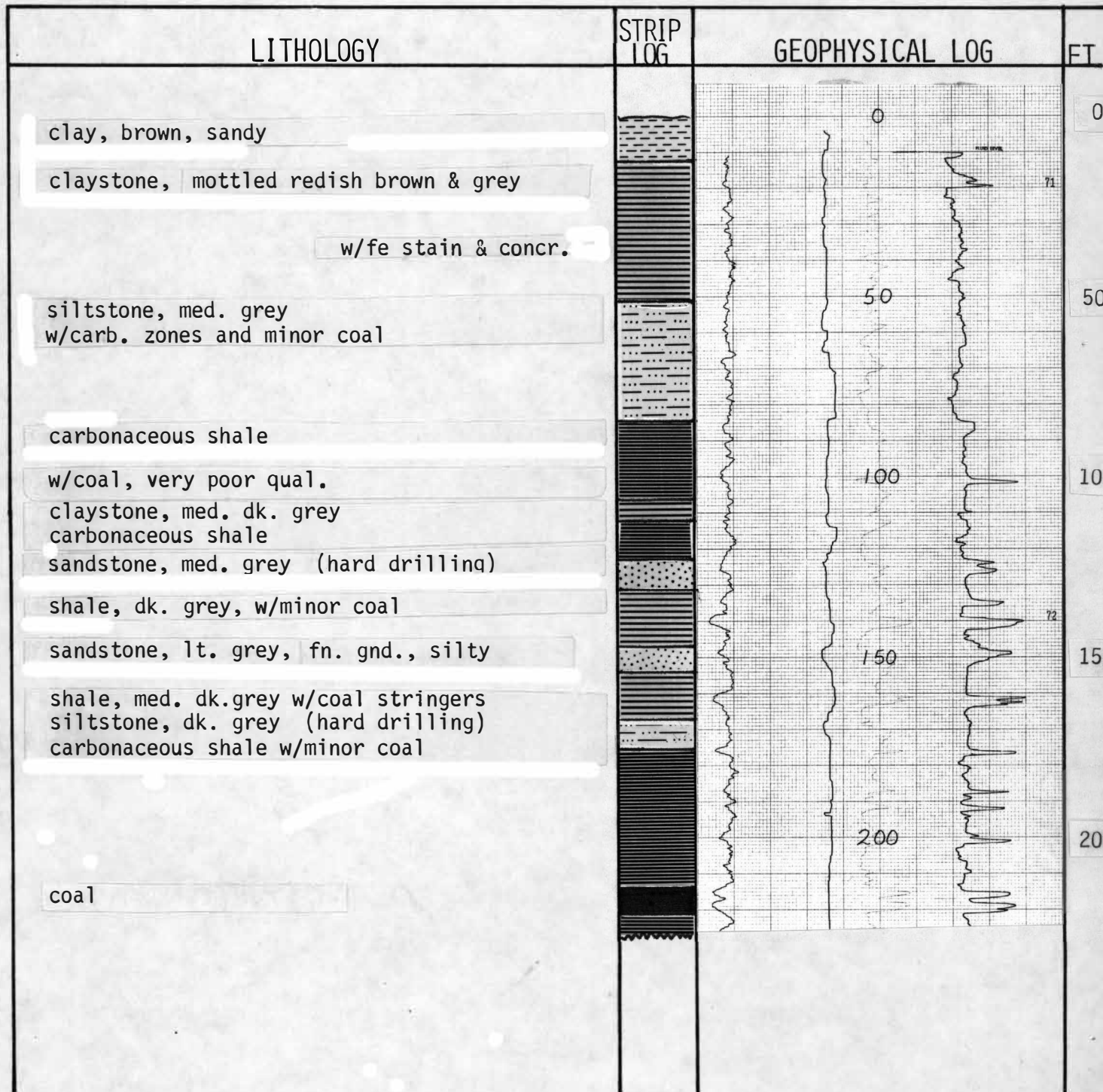

COLORADO GEOLOGICAL SURVEY
Hole No. M-6 - Continued

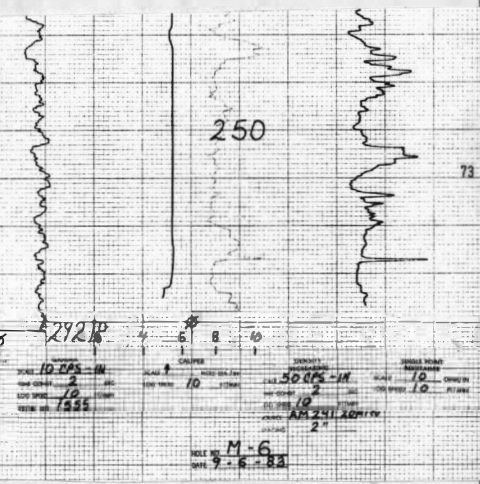
LITHOLOGY	STRIP LOG	GEOPHYSICAL LOG	FT
<p>carbonaceous shale</p> <hr/> <p>coal, poor quality</p> <p>siltstone, med. grey</p> <hr/> <p>shale, dk. grey, non-carb.</p> <p>siltstone & sandstone, med. dk. grey</p> <p>sandstone, lt. grey (soft)</p> <p>T.D. _____</p>			<p>250</p> <hr/> <p>300</p>

COLORADO GEOLOGICAL SURVEY
 TRI-TOWN SUBSIDENCE INVESTIGATION
 DRILL HOLE LOG

Hole No. R-1

Date Logged Sept 8, 1983

Drilled Depth: 242

Logged Depth: 242

Drilling Medium: water

Section: 31

Township: 2N

Range: 67W

Elevation(Ft): 5002

GAMMA LOG		ELECTRIC LOG	
Logged Depth (ft.)	242.238	Logged Depth (ft.)	236.5
Run-in Interval (ft.)		Resistance Scale (ohm-ft)	10
Range Scale (in.)	10 50	5-F Scale (ohm-ft)	
Counts Increasing to:		10-F Normal Resistivity (ohm-in)	
Depth Scale (ft./in.)	10 10	5-F Normal Resistivity (ohm-in)	
Logging Speed (ft./min.)	10 10	Logging Speed (ft./min.)	10
Time Constant(s)	2 2	Viscosity-Density	
Elapsed Time (min.)		Temp. @ 7 1/2'	
IC Factor (x10 ⁴)		Temp. @ 15'	
Water Factor (1 in. hole)		CALIPER LOG	
Caliper Factor (1 in. steel)	1555/1550	Logged Depth (ft.)	236
Probe Dia. (in.)		Scale:	Below 100
Crater Size (in.)		Depth Scale (ft./in.)	10
Probe Dia. (ft.)		Logging Speed (ft./min.)	10
Reference Source (log.)			

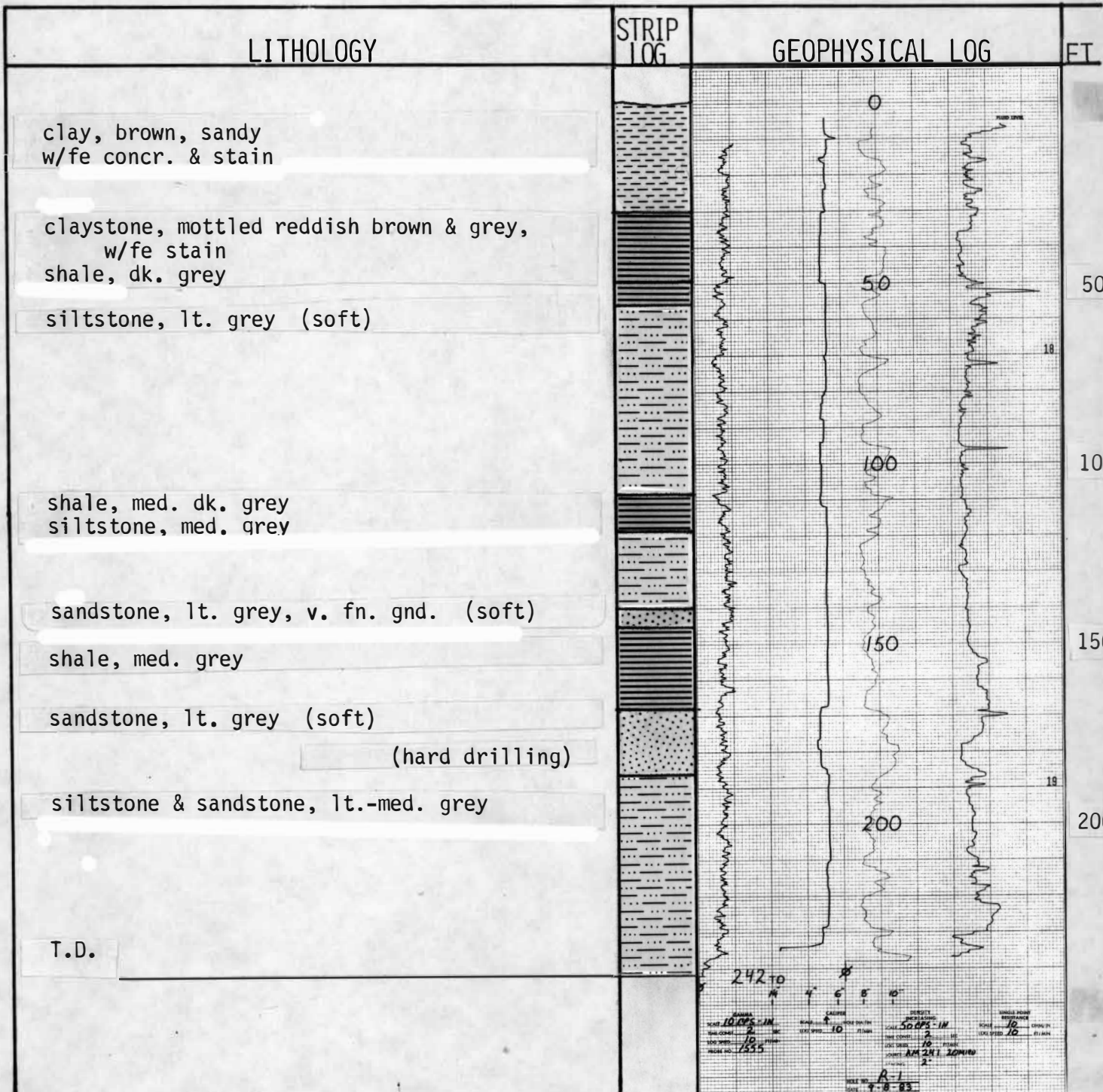

COLORADO GEOLOGICAL SURVEY
 TRI-TOWN SUBSIDENCE INVESTIGATION
 DRILL HOLE LOG

Hole No. R-2

Date Logged: Sept 8, 1983

Drilled Depth: 283

Logged Depth: 283

Drilling Medium: water

Section: 31

Township: 2N

Range: 67W

Elevation(Ft): 5005

GAMMA LOG		ELECTRIC LOG	
Logged Depth (ft.)	283	Logged Depth (ft.)	272.5
Run Interval (ft.)	2.75	Resistance Scale (ohm ft.)	10
Range (ohm ft.)	10	G.P. Scale (ohm ft.)	
Currents Increasing to	10	10° Normal Resistivity (ohm ft.)	
Depth Scale (ft./in.)	10	64° Normal Resistivity (ohm ft.)	
Logging Speed (ft./min.)	10	Logging Speed (ft./min.)	10
Time Constant (sec.)	2	Viscosity Density	
Dead Time (µsec.)	2	Pen. @ 1°F	
K-factor (x10 ³)		Pen. @ 1°F	
Water Factor () in. hole		Pen. @ 1°F	
Casing Factor () in. steel			
Probe Number	1555		
Probe Dia. (in.)	1.56		
Crystal Size (in.)			
Break Out (ft.)			
Reference Source Log			

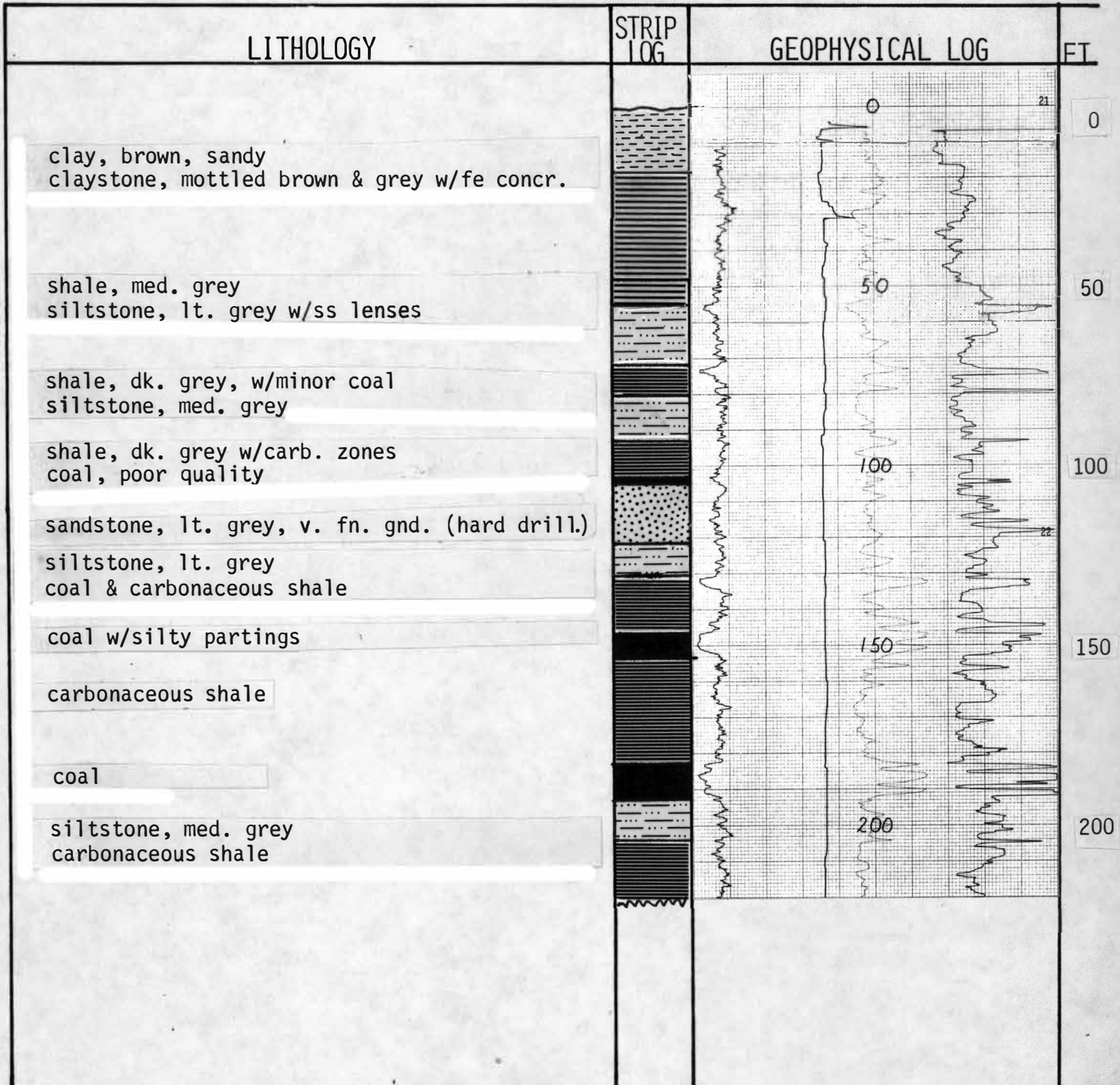

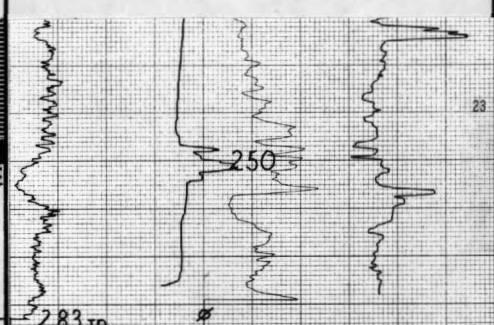
LITHOLOGY	STRIP LOG	GEOPHYSICAL LOG	FT																								
<p>carbonaceous shale</p> <p>coal clay & coal frags. (partial loss of circulation, floor?) unreliable returns</p> <p>T.D.</p>			<p>23</p> <p>250</p>																								
		<table border="1" data-bbox="982 630 1477 798"> <tr> <td>SERIAL</td> <td>SCALE</td> <td>TYPE</td> <td>WELL NO.</td> <td>DATE</td> <td>LOG NO.</td> <td>LOG SPEED</td> <td>LOG SCALE</td> <td>LOG TYPE</td> <td>LOG SPEED</td> <td>LOG SCALE</td> <td>LOG TYPE</td> </tr> <tr> <td>1555</td> <td>500PS-IN</td> <td>2</td> <td>R-2</td> <td>9-8-83</td> <td>10</td> <td>10</td> <td>2</td> <td>10</td> <td>10</td> <td>10</td> <td>10</td> </tr> </table>	SERIAL	SCALE	TYPE	WELL NO.	DATE	LOG NO.	LOG SPEED	LOG SCALE	LOG TYPE	LOG SPEED	LOG SCALE	LOG TYPE	1555	500PS-IN	2	R-2	9-8-83	10	10	2	10	10	10	10	<p>300</p>
SERIAL	SCALE	TYPE	WELL NO.	DATE	LOG NO.	LOG SPEED	LOG SCALE	LOG TYPE	LOG SPEED	LOG SCALE	LOG TYPE																
1555	500PS-IN	2	R-2	9-8-83	10	10	2	10	10	10	10																

COLORADO GEOLOGICAL SURVEY
 TRI-TOWN SUBSIDENCE INVESTIGATION
 DRILL HOLE LOG

Hole No. R-3

Date Logged: Sept 8, 1983

Drilled Depth: 302

Logged Depth: 302

Drilling Medium: water

Section: 31

Township: 2N

Range: 67W

Elevation(Ft): 5008

GAMMA LOG		ELECTRIC LOG	
Logged Depth (ft.)	302, 298	Logged Depth (ft.)	296.5
Run-in Interval (ft.)		Resistance Scale (ohm.)	
Range Scale (in.)	10 50	G.P. Scale (inches)	
Counts increasing to	10 50	10" Normal Resistivity (ohm-in)	
Depth Scale (ft. An.)	10 10	50" Normal Resistivity (ohm-in)	
Logging Speed (ft./min.)	10 10	Logging Speed (ft./min.)	
Time (start/stop)	2 2	Viscosity-Density	
Dead Time (sec)		Temp. @ 1" F	
K factor (x10 ³)		Temp. @ 1" F	
Water Factor (1 in. hole)		Temp. @ 1" F	
Casing Factor (1 in. steel)		Temp. @ 1" F	
Probe Number	1555/1550	Temp. @ 1" F	
Probe Dia. (in.)		Temp. @ 1" F	
Crystal Size (in.)		Temp. @ 1" F	
Print Out (ft.)		Temp. @ 1" F	
Reference Source (ppm)		Temp. @ 1" F	

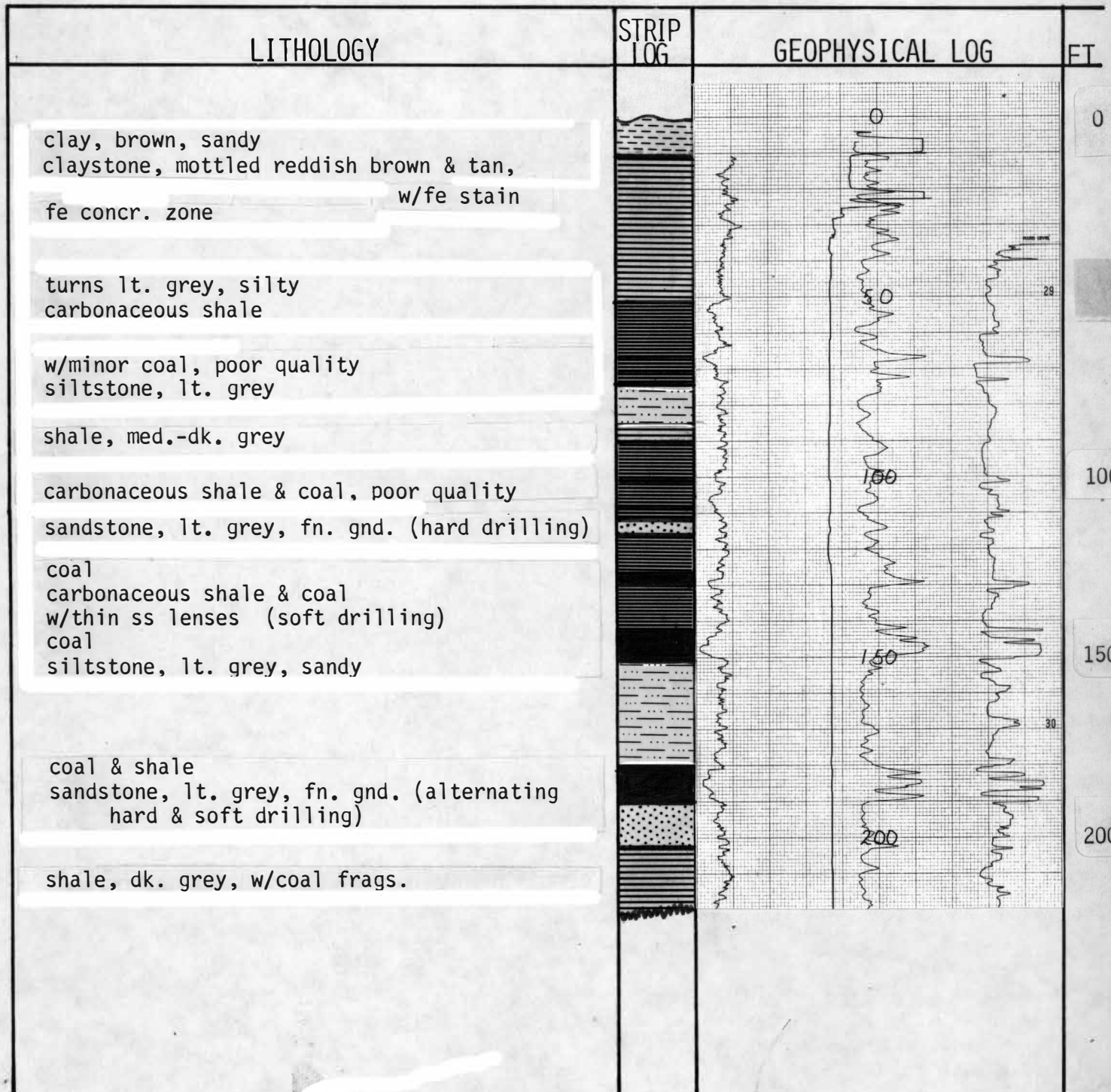

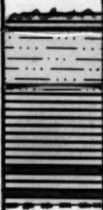
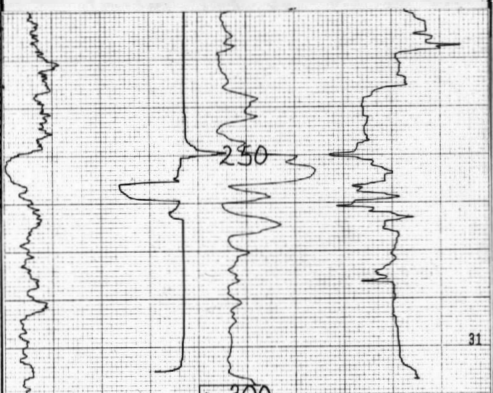
LITHOLOGY	STRIP LOG	GEOPHYSICAL LOG	FT
<p>siltstone & sandstone, lt.-med. grey</p> <p>shale, med.-dk. grey w/coal stringers</p> <p>(lost circulation @ + 265', no returns)</p>			<p>250</p> <p>300</p>
<p>T.D.</p>		<p>302 TD 14"</p> <p>300</p> <p>4 6 8 10'</p> <p>CORNER SCALE 10 CM - IN TRAIL CODE 2 LOG SPEED 10 ROD SIZE 10 LOG DATE 10 CORNER SCALE 50 CM - IN TRAIL CODE 2 LOG SPEED 10 CORNER SCALE 10 CORNER</p> <p>FILE NO. 1555</p> <p>AM 31-20-04</p> <p>R-3</p> <p>9-8-83</p>	

COLORADO GEOLOGICAL SURVEY
 TRI-TOWN SUBSIDENCE INVESTIGATION
 DRILL HOLE LOG

Hole No. R-4

Date Logged: Sept 8, 1983

Drilled Depth: 302

Logged Depth: 302

Drilling Medium: water

Section: 31



Township: 2N

Range: 67W

Elevation(Ft): 5011

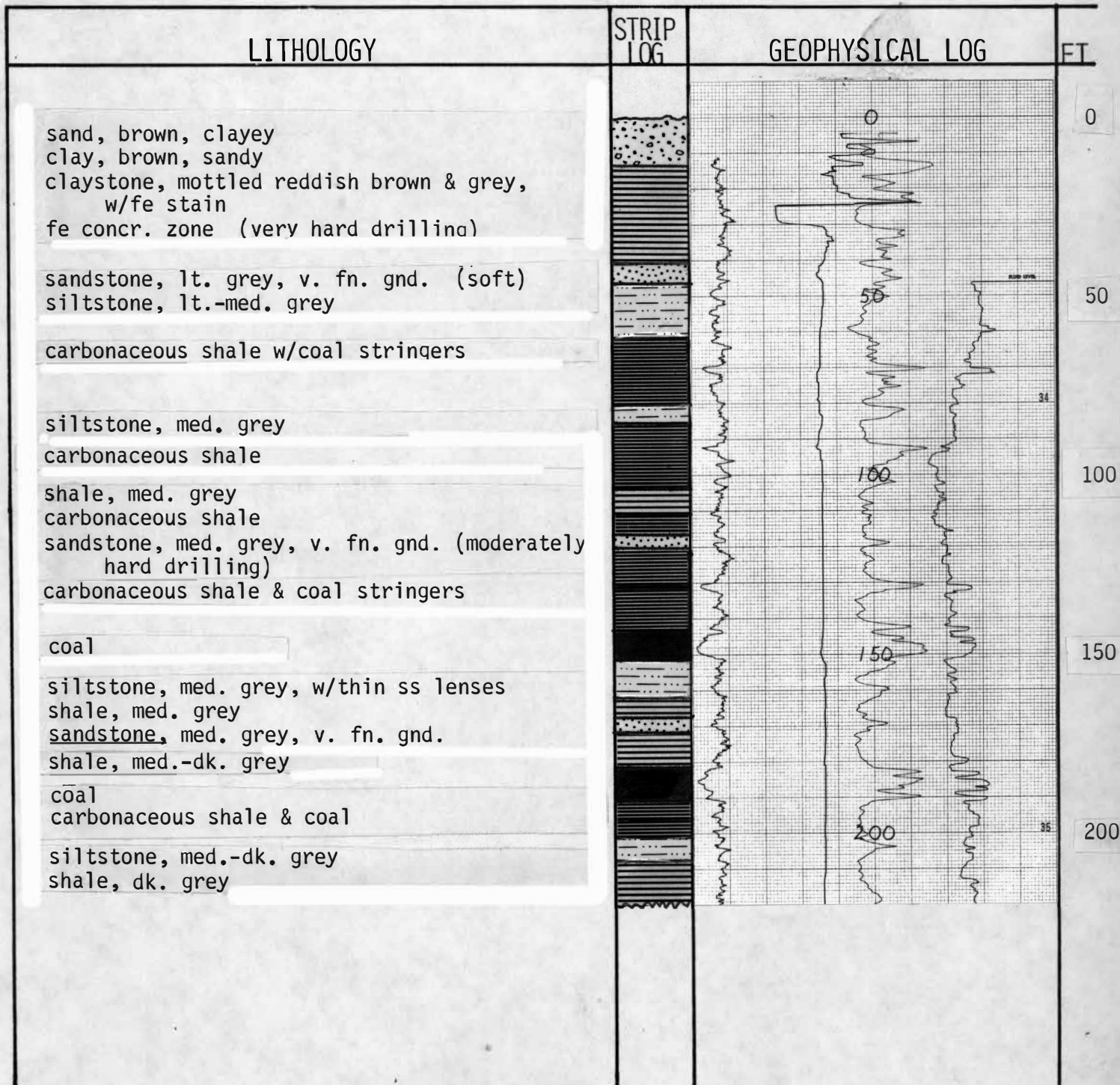
GAMMA LOG		ELECTRIC LOG	
Logged Depth (ft.)	302 298	Logged Depth (ft.)	296.5
Run-in Interval (ft.)		Reference Scale (ft.)	70
Change Log (in.)	10 50	S.P. Scale (in.)	
Counts Increasing to		10' Normal Resistivity (ohm-in.)	
Depth Scale (ft./in.)	10 10	60' Normal Resistivity (ohm-in.)	
Logging Speed (ft./min.)	10 10	Logging Speed (ft./min.)	10
Time Constant (sec.)	2 2	Velocity-Density	
Sheet Time (sec.)		Pen. @ 7 1/2'	
K-factor (x10 ³)		Pen. @ 15'	
Water Factor () in hole		Pen. @ 30'	
Calving Factor () in steel		Pen. @ 45'	
Probe No. (in.)	1555/1550	Pen. @ 60'	
Crystal Size (in.)		Pen. @ 75'	
Print Out (ft.)		Pen. @ 90'	
Reference Source (logs.)		Pen. @ 105'	
		Pen. @ 120'	
		Pen. @ 135'	
		Pen. @ 150'	
		Pen. @ 165'	
		Pen. @ 180'	
		Pen. @ 195'	
		Pen. @ 210'	
		Pen. @ 225'	
		Pen. @ 240'	
		Pen. @ 255'	
		Pen. @ 270'	
		Pen. @ 285'	
		Pen. @ 300'	



LITHOLOGY	STRIP LOG	GEOPHYSICAL LOG	FT
carbonaceous shale & coal			
clay and coal frags. (floor?) (lost circulation @ ± 260, no returns)			250
T.D.			300
		<div style="text-align: center;">   </div> <p> <small> SAMPLES SCALE 10 CPS. IN TIME CORRECTED SCALE 10 LOG NO. 1555 CALIPER LOG NO. 10 DENBITY INCREASING FROM 50 CPS. IN LOG NO. 10 LOG NO. 1555 SCALE 2 LOG NO. 10 LOG NO. 1555 SCALE 2 LOG NO. 10 LOG NO. 1555 SCALE 2 LOG NO. 10 LOG NO. 1555 </small> </p> <p style="text-align: center;"> <small> HOLE NO. R-4 DATE 9-9-83 </small> </p>	

COLORADO GEOLOGICAL SURVEY
 TRI-TOWN SUBSIDENCE INVESTIGATION
 DRILL HOLE LOG

Hole No. R-5

Date Logged: Sept 9, 1983

Drilled Depth: 283

Logged Depth: 283

Drilling Medium: water

Section: 31

Township: 2N

Range: 67W

Elevation(Ft): 5018

GAMMA LOG		Time	06M	Run-in
Logged Depth (ft.)	283	274		
Return Interval (ft.)				
Range (cps/in.)	10	50		
Counts Increasing to:				
Depth Scale (ft./in.)	10	10		
Logging Speed (ft./min.)	10	10		
Time Constant(s)				
Dead Time (μsec)				
K-factor (x10 ³)				
Water Factor () in. hole				
Casing Factor () in. steel				
Probe Number		1555155A		
Probe Dia. (in.)				
Crystal Size (in.)				
Probe Out (ft.)				
Reference Source (cps)				

ELECTRIC LOG	
Logged Depth (ft.)	277
Reference Scale (ft./in.)	10
G. P. Scale (cm/in.)	
10° Normal Resistivity (Ωm/in.)	
50° Normal Resistivity (Ωm/in.)	
Logging Speed (ft./min.)	10
Velocity (ft./min.)	
Arm. @ 17'	
Arm. @ 17'	

CALIPER LOG	
Logged Depth (ft.)	277
Scale	BELOW LOG
Depth Scale (ft./in.)	10
Logging Speed (ft./min.)	10

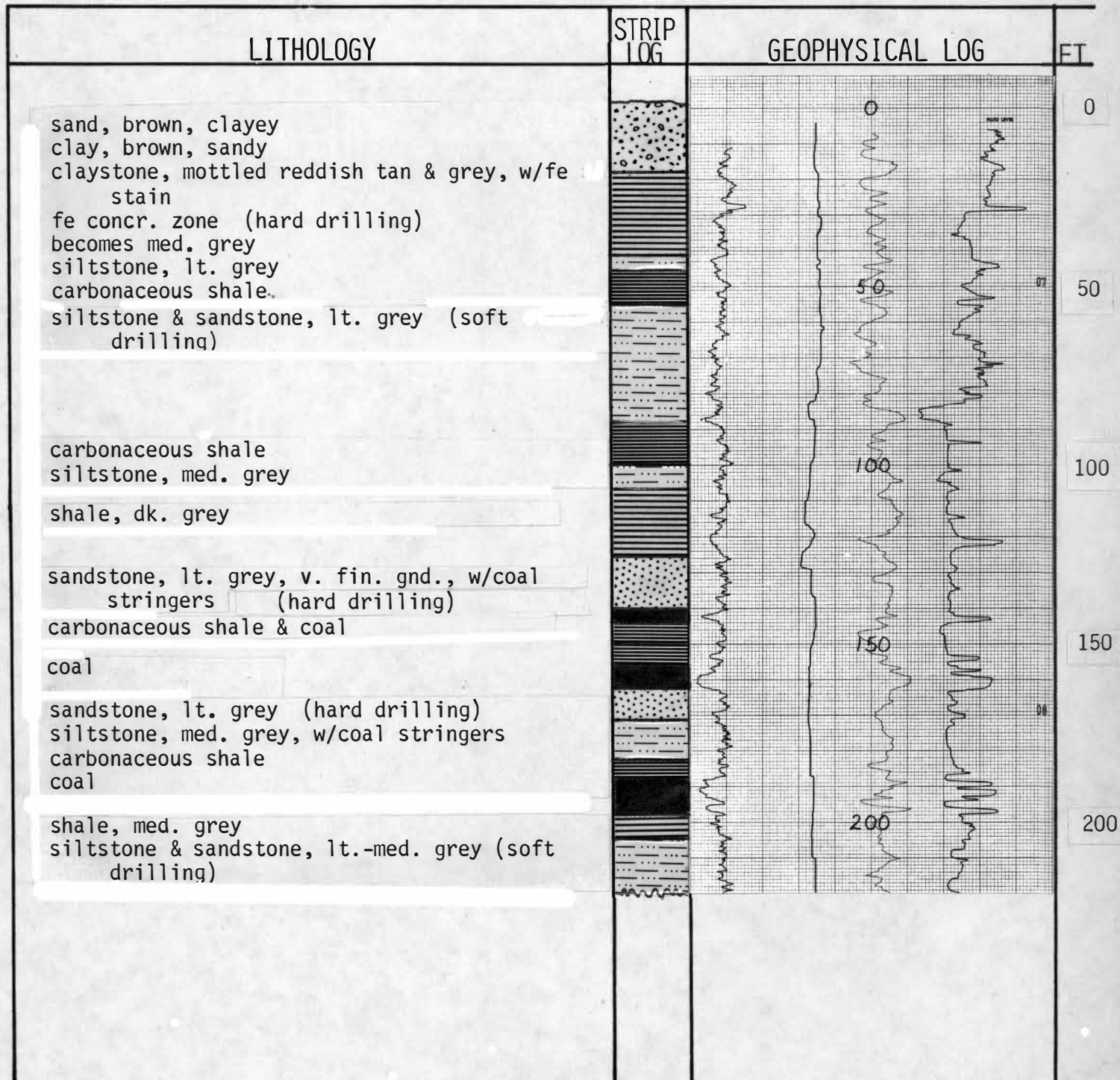

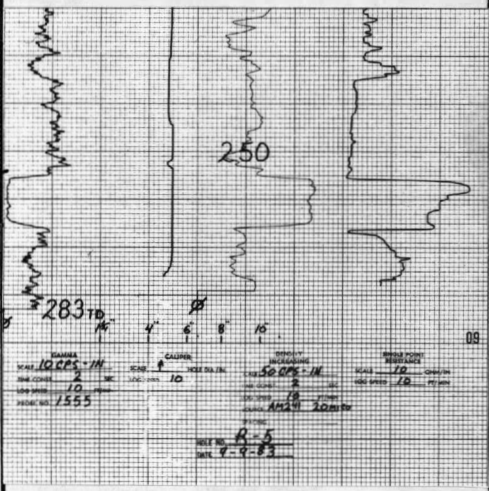
LITHOLOGY	STRIP LOG	GEOPHYSICAL LOG	FT
carbonaceous shale coal siltstone & sandstone, med. grey (soft drilling) T.D.			<div style="margin-bottom: 100px;">250</div> <div>300</div>

COLORADO GEOLOGICAL SURVEY
 TRI-TOWN SUBSIDENCE INVESTIGATION
 DRILL HOLE LOG

Hole No. R-6A

Date Logged: Sept 8, 1983

Drilled Depth: 281

Logged Depth: 281

Drilling Medium: water

Section: 31

Township: 2N

Range: 67W

Elevation(Ft): 5020

GAMMA LOG		ELECTRIC LOG	
Logged Depth (ft.)	281, 277	Logged Depth (ft.)	278.5
Run-in Interval (ft.)		Resistance Scale (ohm-ft)	10
Range (ohm-ft)	10 - 50	S.P. Scale (mv)	
Counts Increasing to	10 - 10	16° Normal Resistivity (ohm-ft)	
Depth Scale (ft., in.)	10 10	64° Normal Resistivity (ohm-ft)	
Logging Speed (ft./min.)	10 10	Logging Speed (ft./min.)	10
Time Constant(sec.)	2 2	Viscosity-Density	
Dead Time (sec.)		Res. @ 17°	
K-factor (x10 ³)		Res. @ 17°	
Water Factor (1 in. hole)		CALIPER LOG	
Corelog Factor (1 in. hole)		Logged Depth (ft.)	275
Probe Number	1555/1550	Scale:	BELOW LOG
Probe Dia. (in.)		Depth Scale (ft., in.)	10
Crystal Size (in.)		Logging Speed (ft./min.)	10
Print Out (ft.)			
Reference Source (top)			

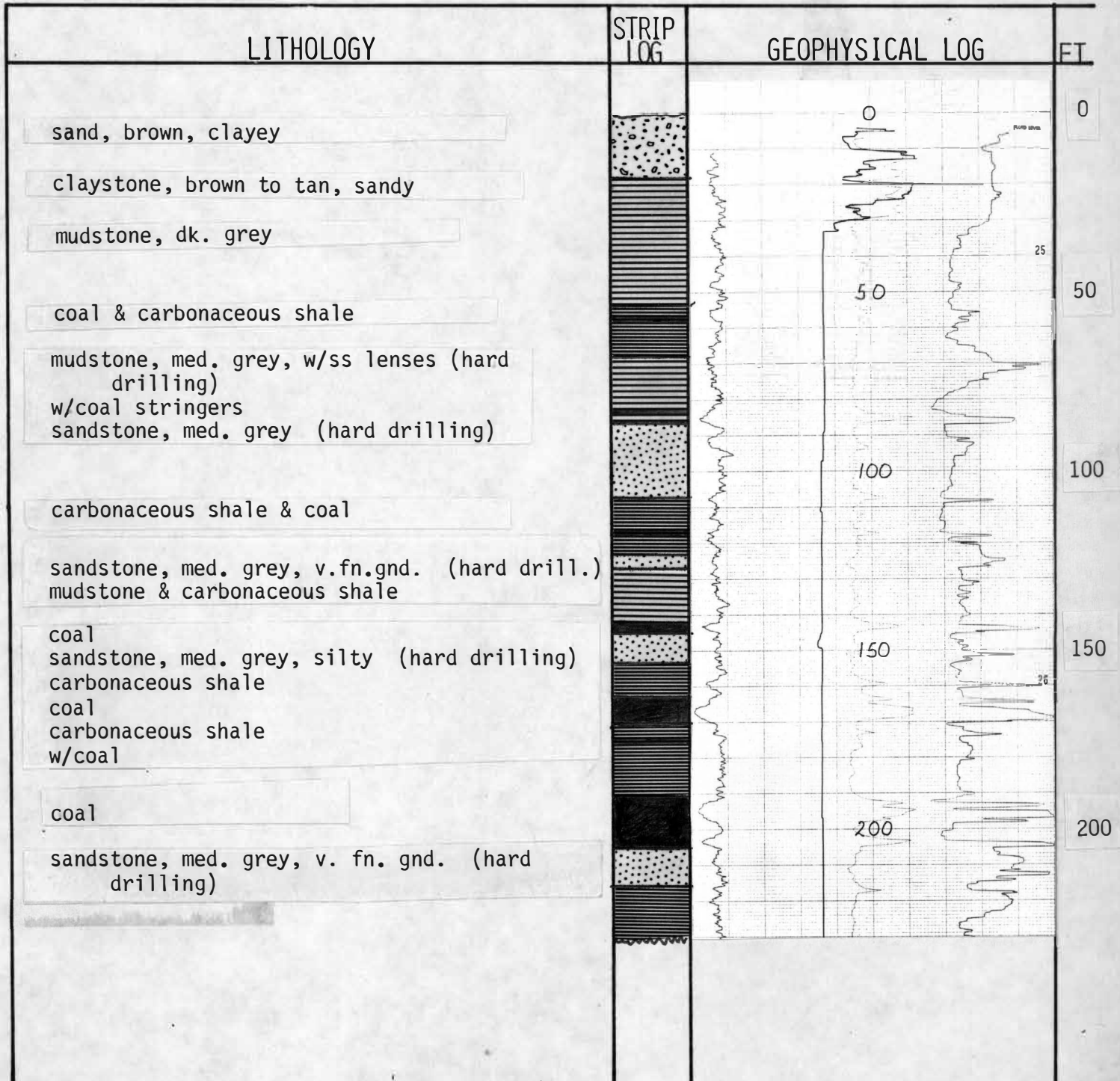

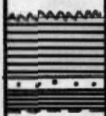
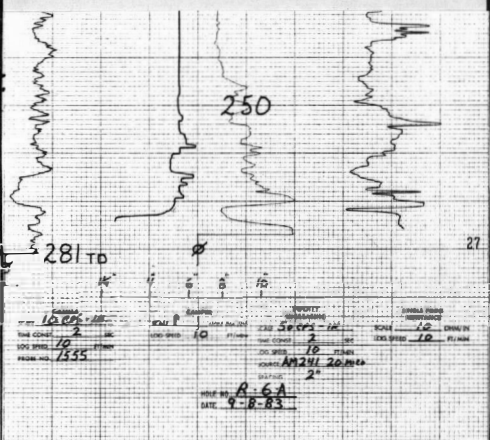
LITHOLOGY	STRIP LOG	GEOPHYSICAL LOG	FT
<p>shale, med. grey, minor carb. sandstone, lt. grey carbonaceous shale (lost circulation @ \pm 250', no returns)</p> <p>T.D.</p>		 <p>250</p> <p>281 TD</p> <p>PROPERTY: 5602-10 WELL NO: 10 DATE: 9-8-85</p>	<p>27</p> <p>300</p>

Appendix B

Subsidence Profiles
(see Plate 2 for locations)

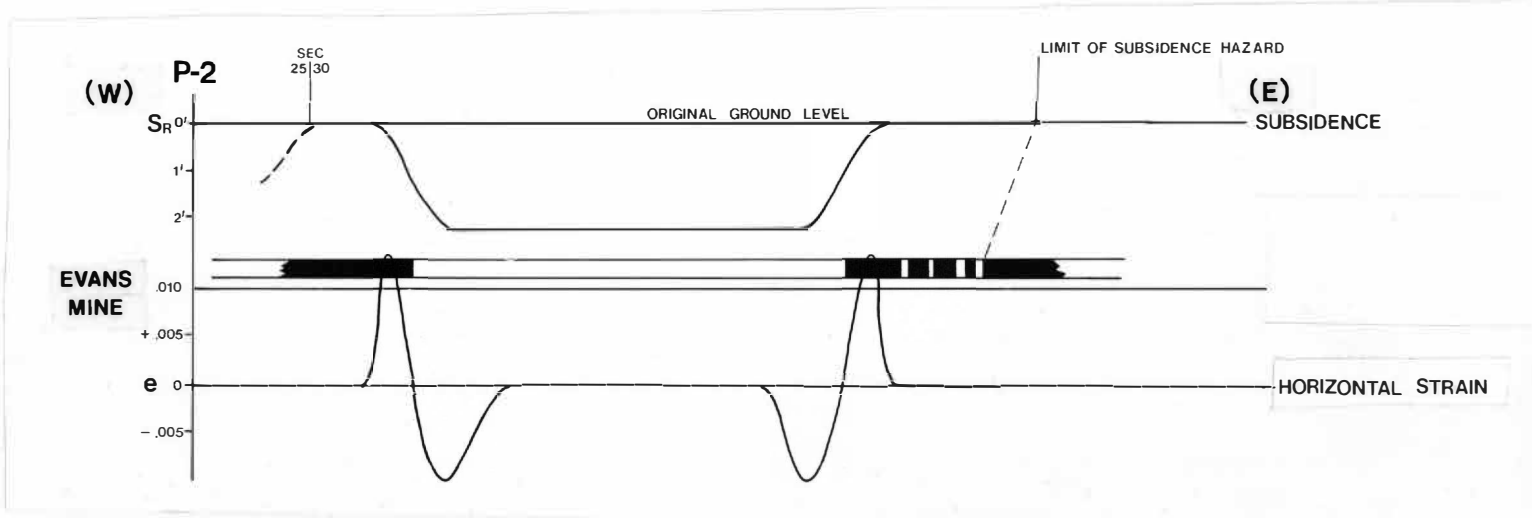
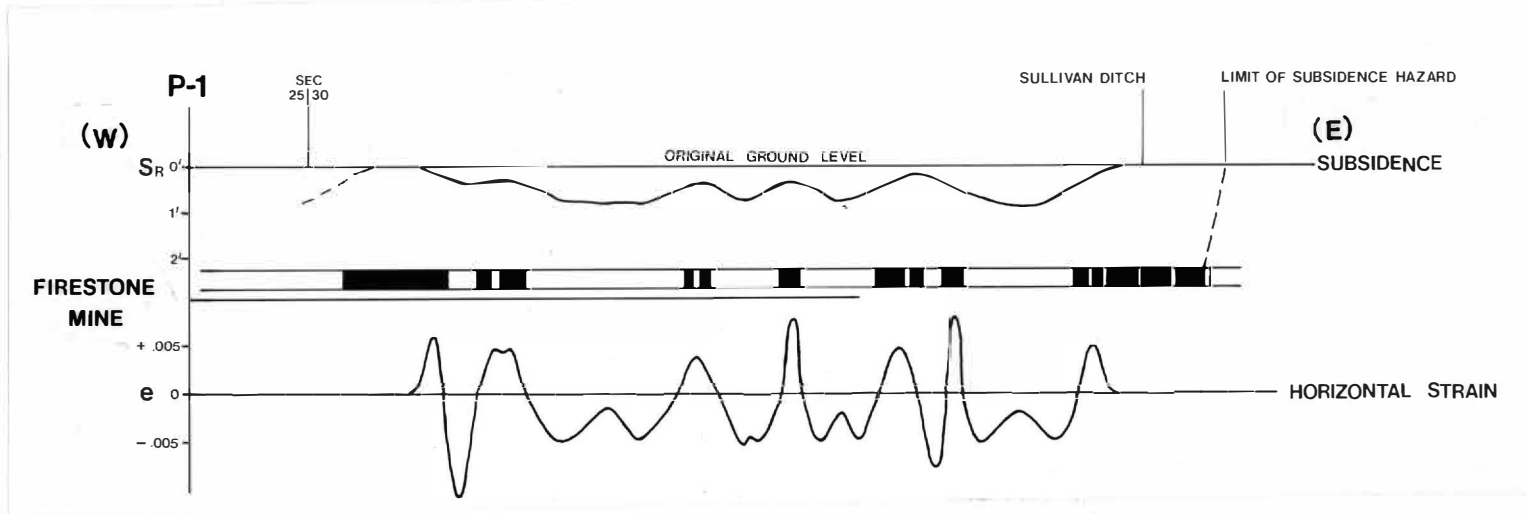

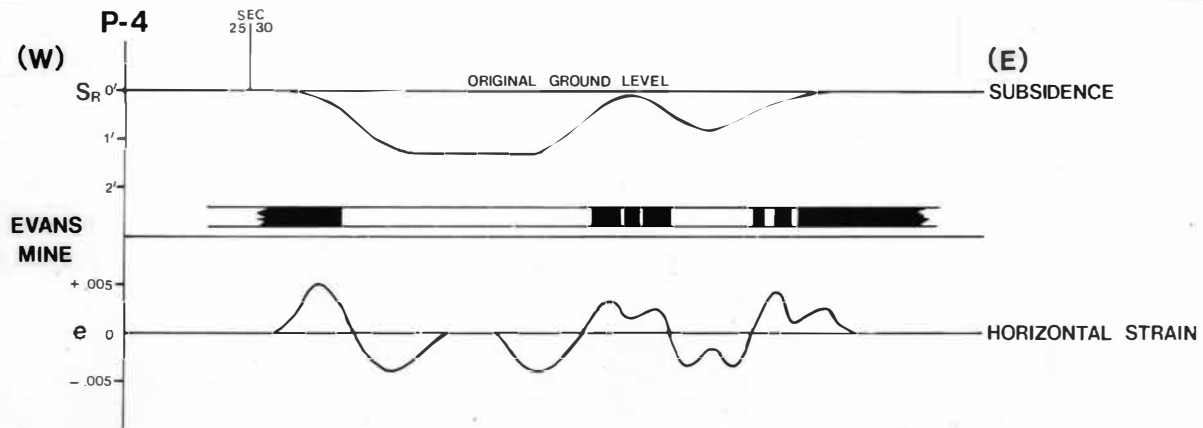
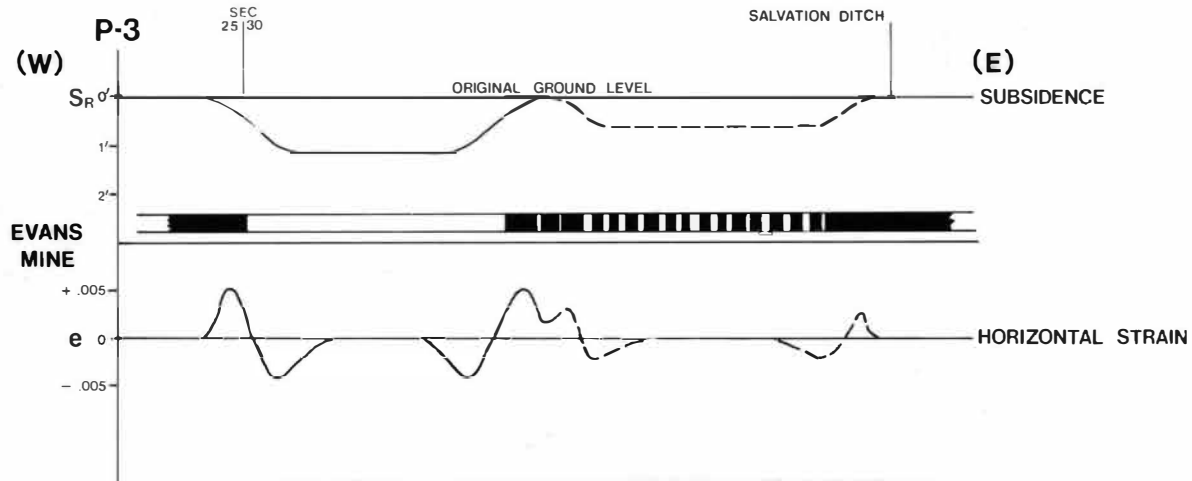

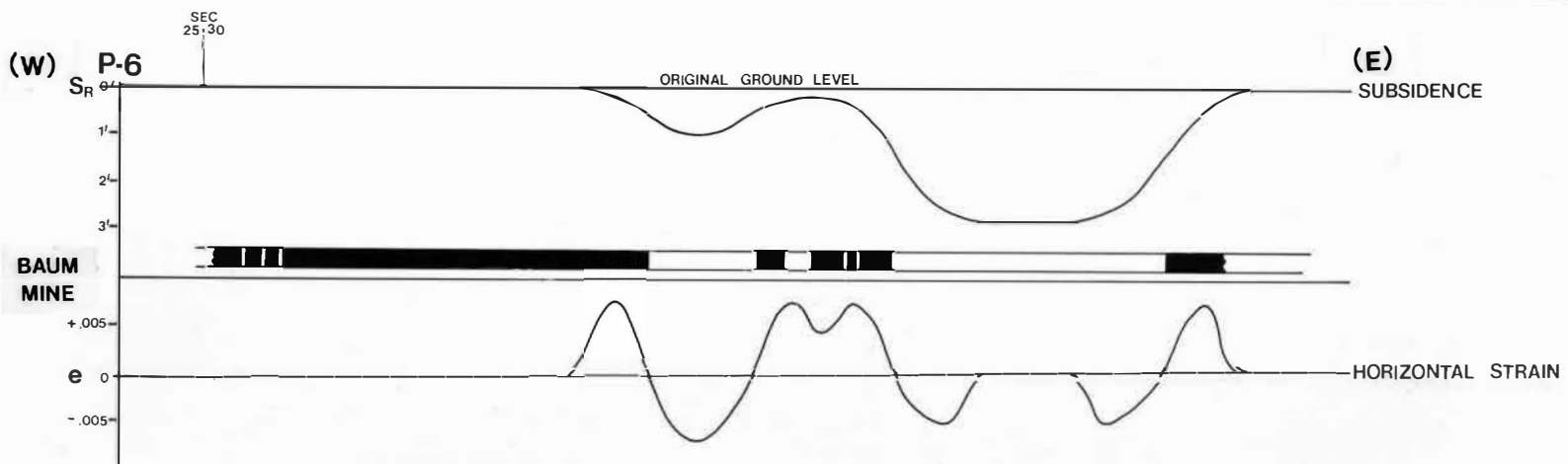
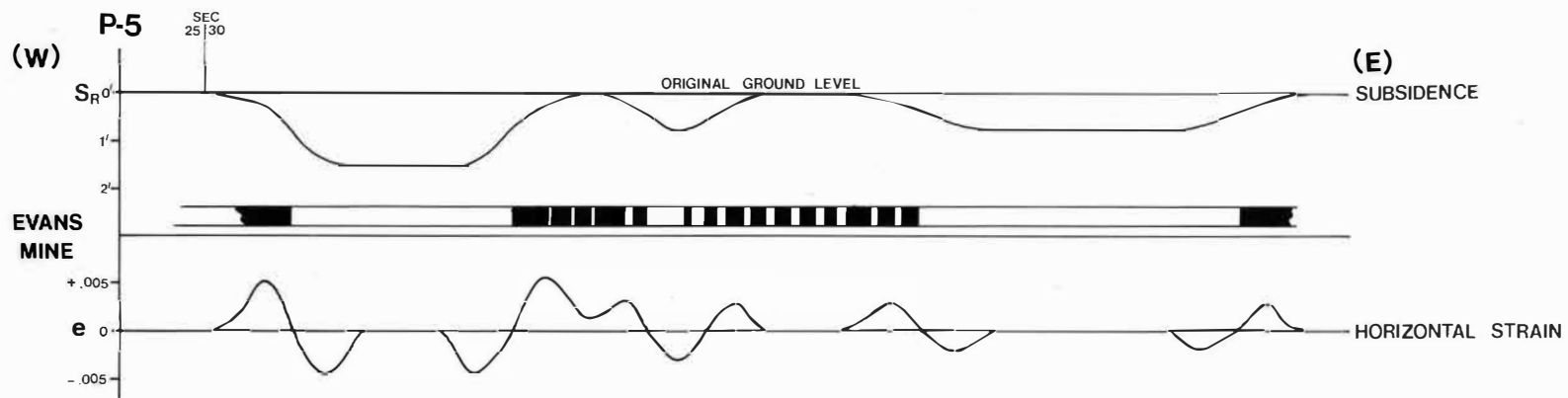

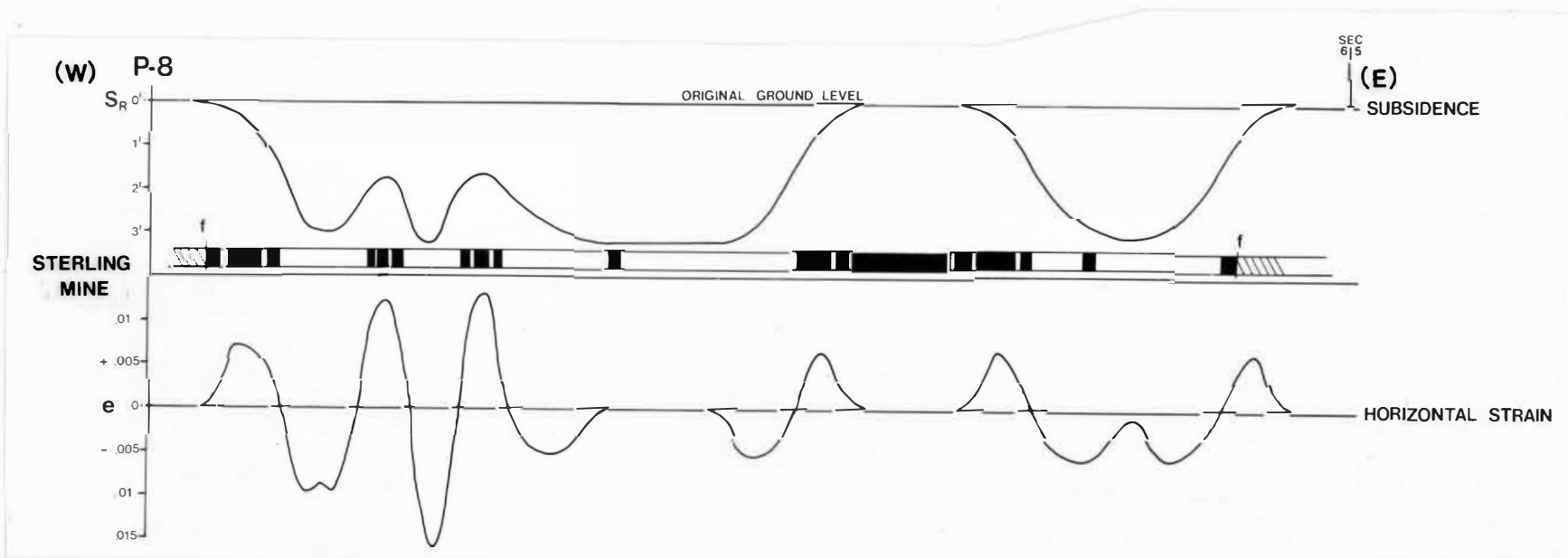
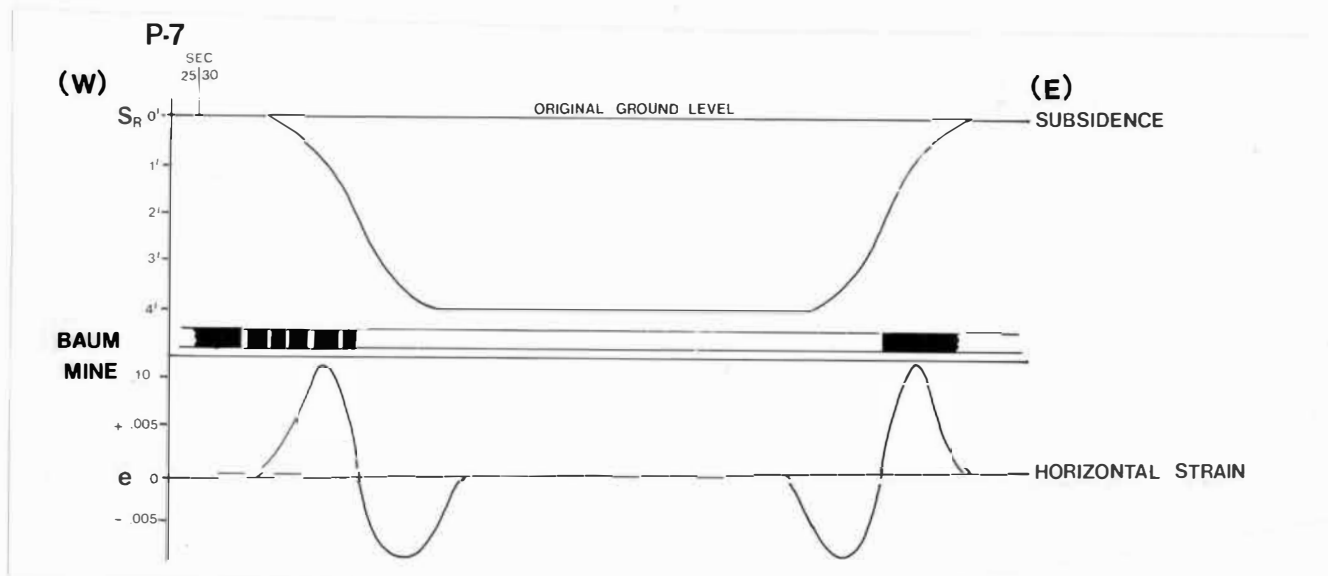

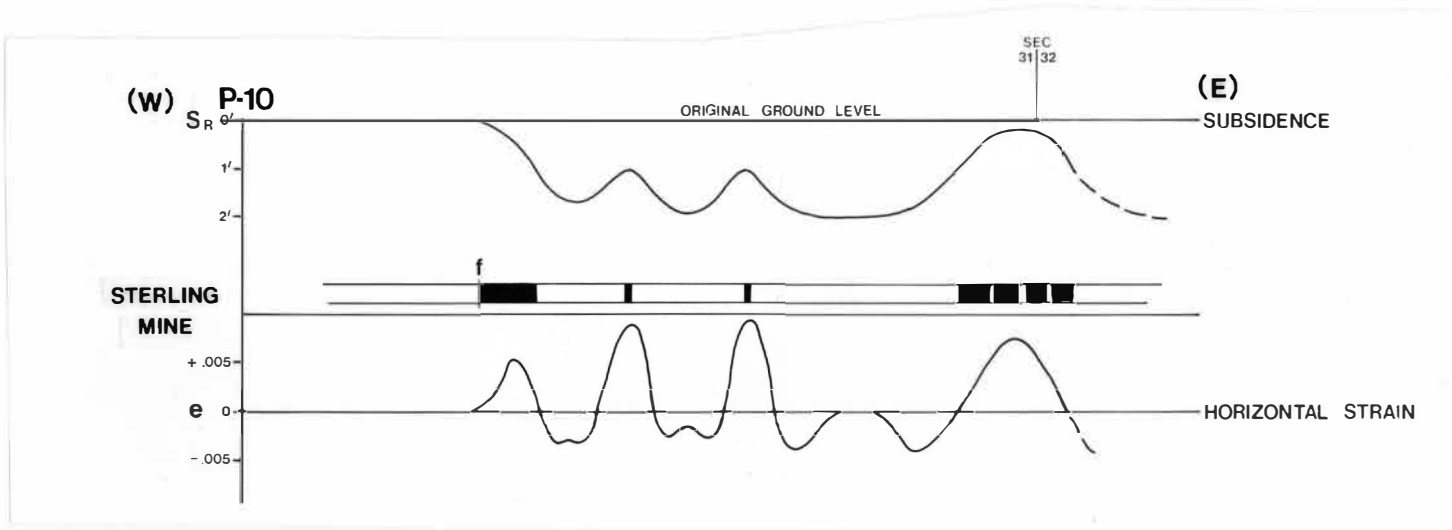
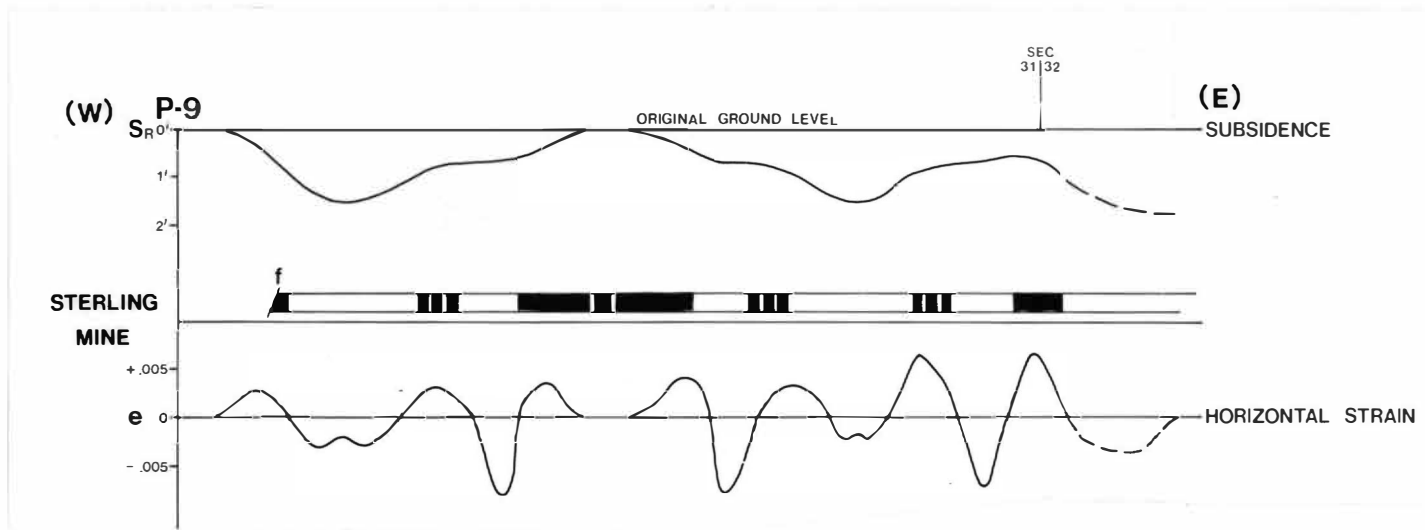

B-6

